

Rome 2012



ETS·LINDGREN[™]
An ESCO Technologies Company

Enabling Your Success

Introduction to MIMO OTA Environment Simulation, Calibration, Validation, and Measurement Results

Dr. Michael D. Foegelle
Director of Technology Development

Garth D'Abreu
Director of RF Engineering

WWW.ETS-LINDGREN.COM

Outline

- **The Meaning of MIMO**
- **MIMO and the RF Environment**
- **The Channel Emulator**
- **Understanding the Channel Model**
- **Implications of OTA Testing**
- **Spatial Environment Simulation**
- **ETS-Lindgren AMS-8700**

Outline

- **Calibrating the System**
- **System Validation**
- **Wi-Fi and LTE Throughput Measurement Results with the ETS-Lindgren AMS-8700 OTA Environment Simulator**
- **Metrics**
- **Reference MIMO Antennas**

The Meaning of MIMO

- **MIMO stands for *Multiple Input, Multiple Output* and refers to the characteristics of the *communication channel(s)* between two devices.**
- **In communication theory, a channel is the path by which the data gets from an input (transmitter) to an output (receiver).**
 - For Ethernet or USB, the channel is the cable used.
 - For wireless, the channel includes the RF frequency bandwidth, the space between antennas, and anything that reflects RF energy from one point to the other.
 - Often includes antennas and cables too.

The Meaning of MIMO

- **The term MIMO is often used to represent a range of bandwidth/performance enhancing technologies that rely on multiple antennas in a wireless device.**
- **These can be classified into several categories:**
 - “True” Spatial Multiplexing MIMO.
 - SIMO (Single Input, Multiple Output) technologies like beam forming and receive diversity.
- **While this discussion will concentrate on downlink MIMO, uplink MIMO/MISO concepts are similar.**

The Meaning of MIMO

- **“True” MIMO uses multiple transmit and receive antennas to increase the total information bandwidth through time-space coding.**
 - Multiple channels of communication (streams) share the same frequency bandwidth allocation simultaneously.



The Meaning of MIMO

- SIMO technologies use the multiple (receive) antennas to improve single channel performance under edge-of-link (EOL) conditions.
- Beam forming allows creating a stronger gain pattern in the direction of the desired signal while simultaneously rejecting undesired signals from other directions.

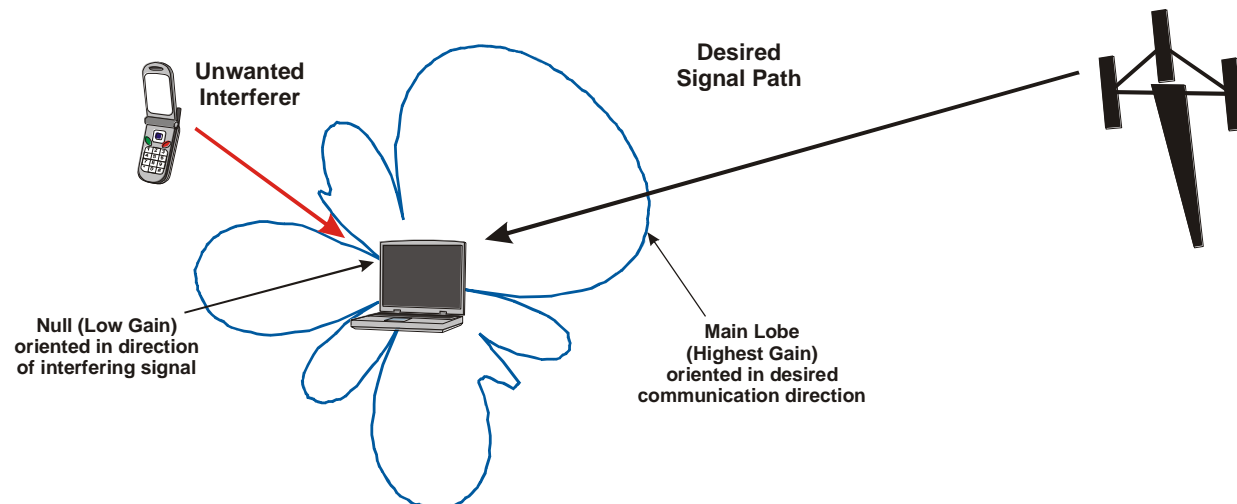

The Meaning of MIMO

- **Receive diversity uses multiple antennas to overcome channel fades by using additional antenna(s) to capture additional information that may be missing from the first channel.**
 - Includes simple switching diversity or more complicated techniques like maximal ratio combining or other combinatorial diversity techniques.

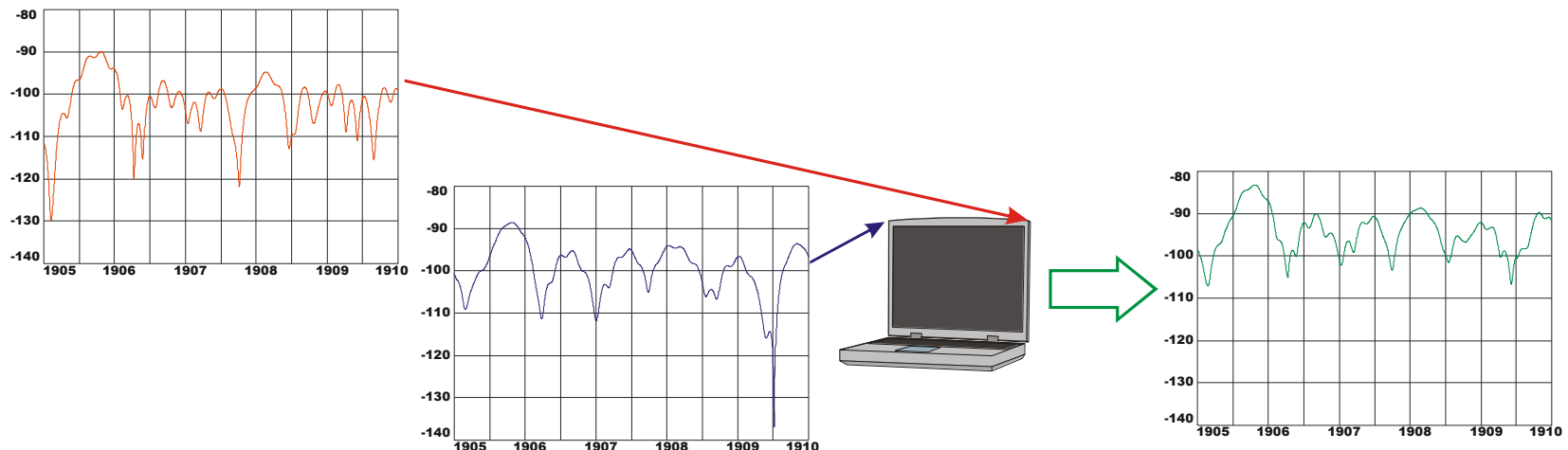

MIMO and the RF Environment

- All of these multiple antenna technologies share one thing in common – their performance is a function of the environment in which they're used.
- The device adapts to its environment through embedded algorithms that change its (effective) radiation pattern.

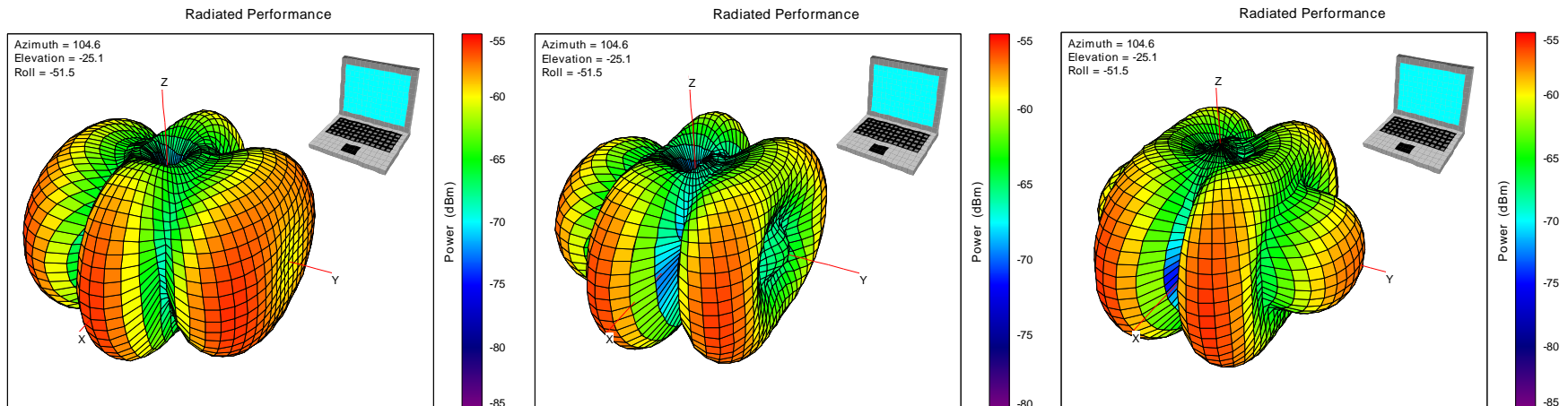

MIMO and the RF Environment

- **Traditional TRP and TIS metrics are properties of the mobile device only. These represent the average performance of the device to signals from any direction.**

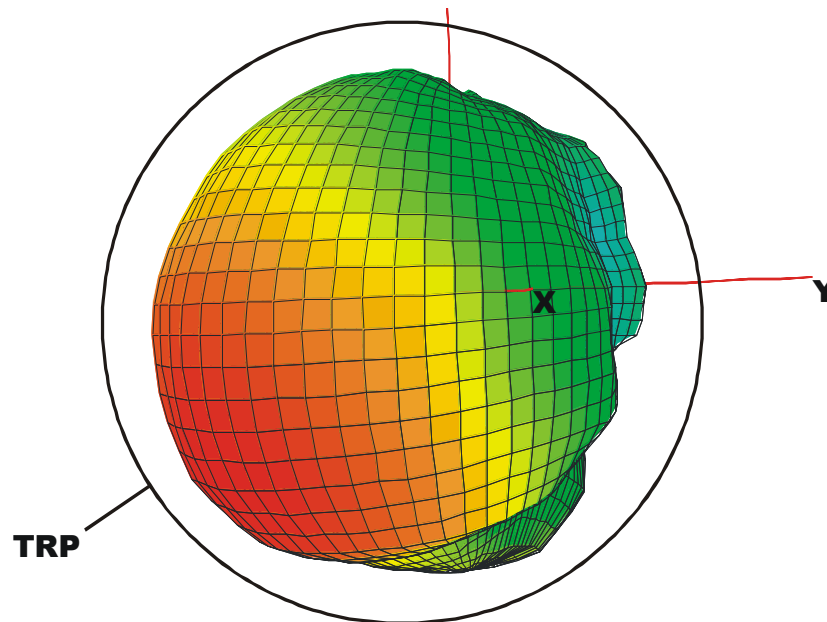

MIMO and the RF Environment

- Metrics like Near Horizon Partial Radiated Power/Sensitivity terms or Mean Effective Gain apply simple environmental models to fixed pattern data, but the basic behavior of the device does not change.

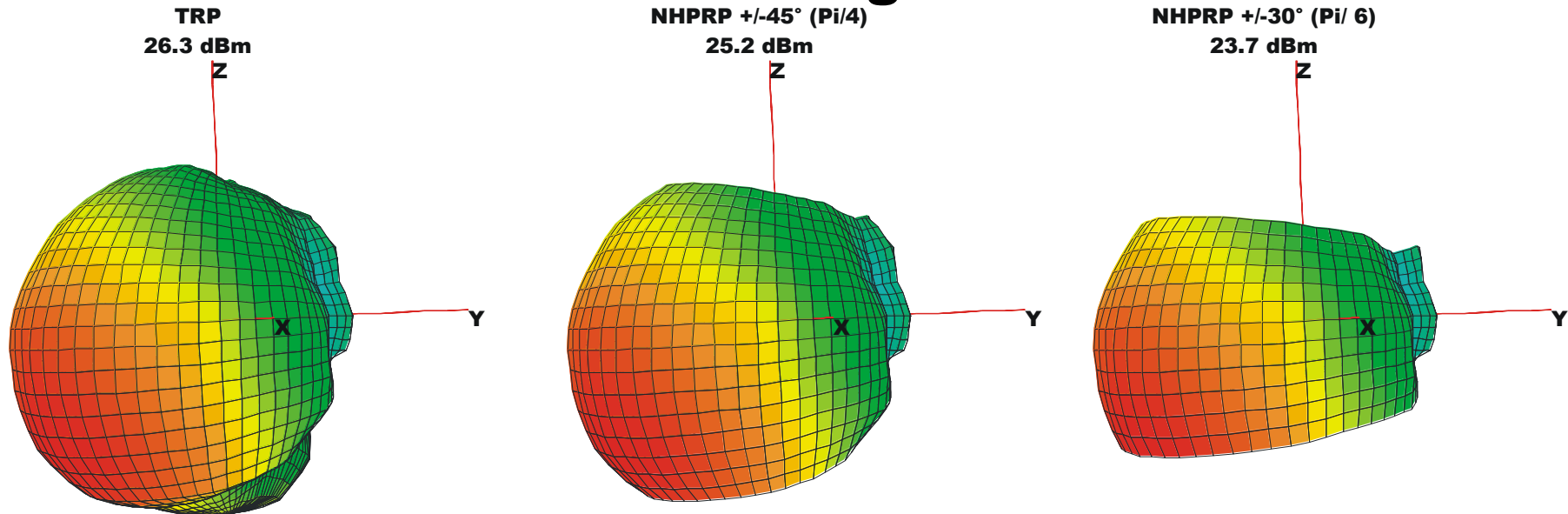

MIMO and the RF Environment

- For MIMO technologies, performance is a function of the system and cannot be restricted to the mobile device.

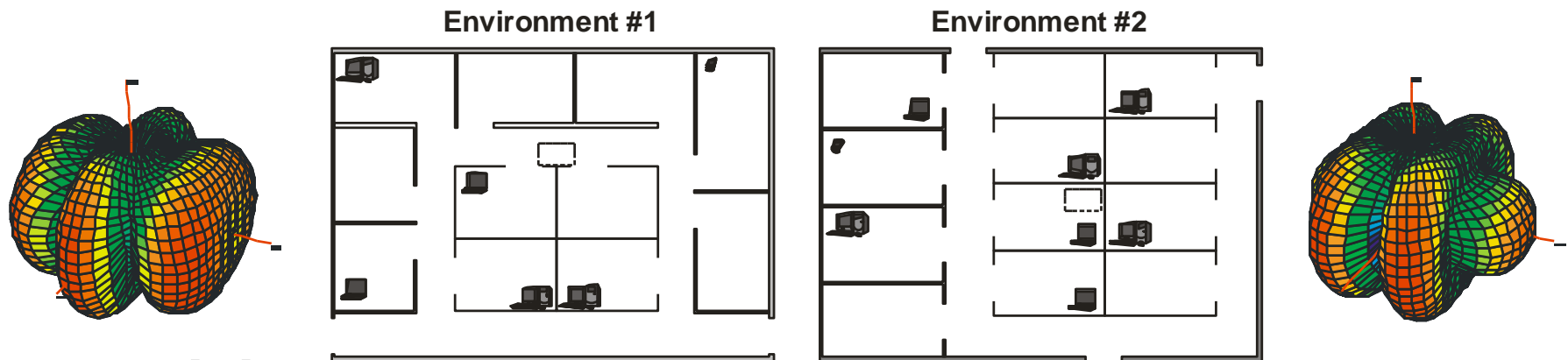

- Individual device performance can only be evaluated or compared *in a given environment*.
- This implies the need for environment simulation.

The Channel Emulator

- **A *channel emulator* is typically used for conducted testing of MIMO radios.**
- **The channel emulator simulates the wireless channel between transmit and receive radios using a *channel model*.**
- **Channel models simulate not only a given environment, but also properties of the base station and mobile device including antenna patterns, antenna separation, and angles of departure/arrival (AOD/AOA).**

The Channel Emulator

- A typical RF channel emulator consists of a number of VSA receivers and VSG transmitters connected to a DSP modeling core that introduces delay spreads, fading, etc. at baseband.

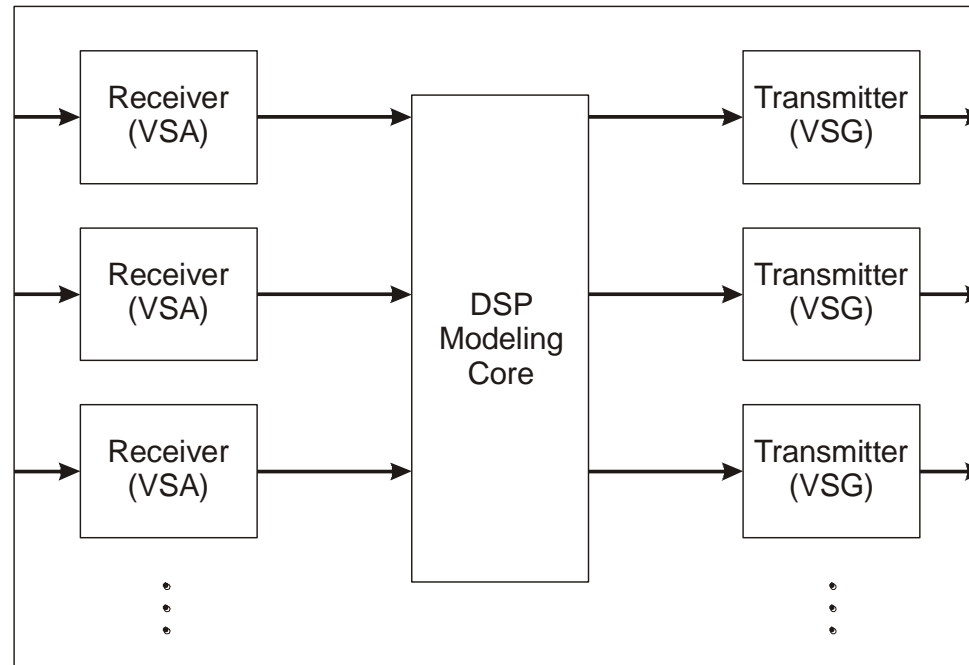

The Channel Emulator

- The ideal channel emulator routes multiple inputs to multiple outputs after applying appropriate modeled delay spreads, fading, etc.

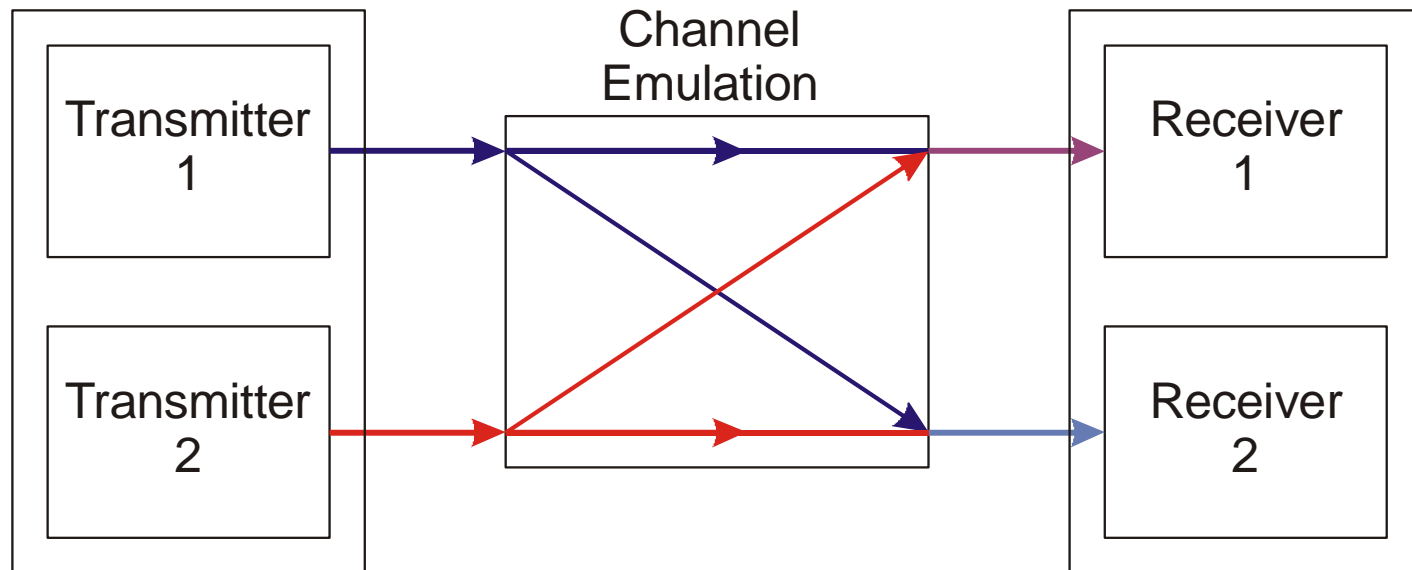

Understanding the Channel Model

- In the real world, various objects in the environment cause reflections of the transmitted signal that are seen at the receiver.

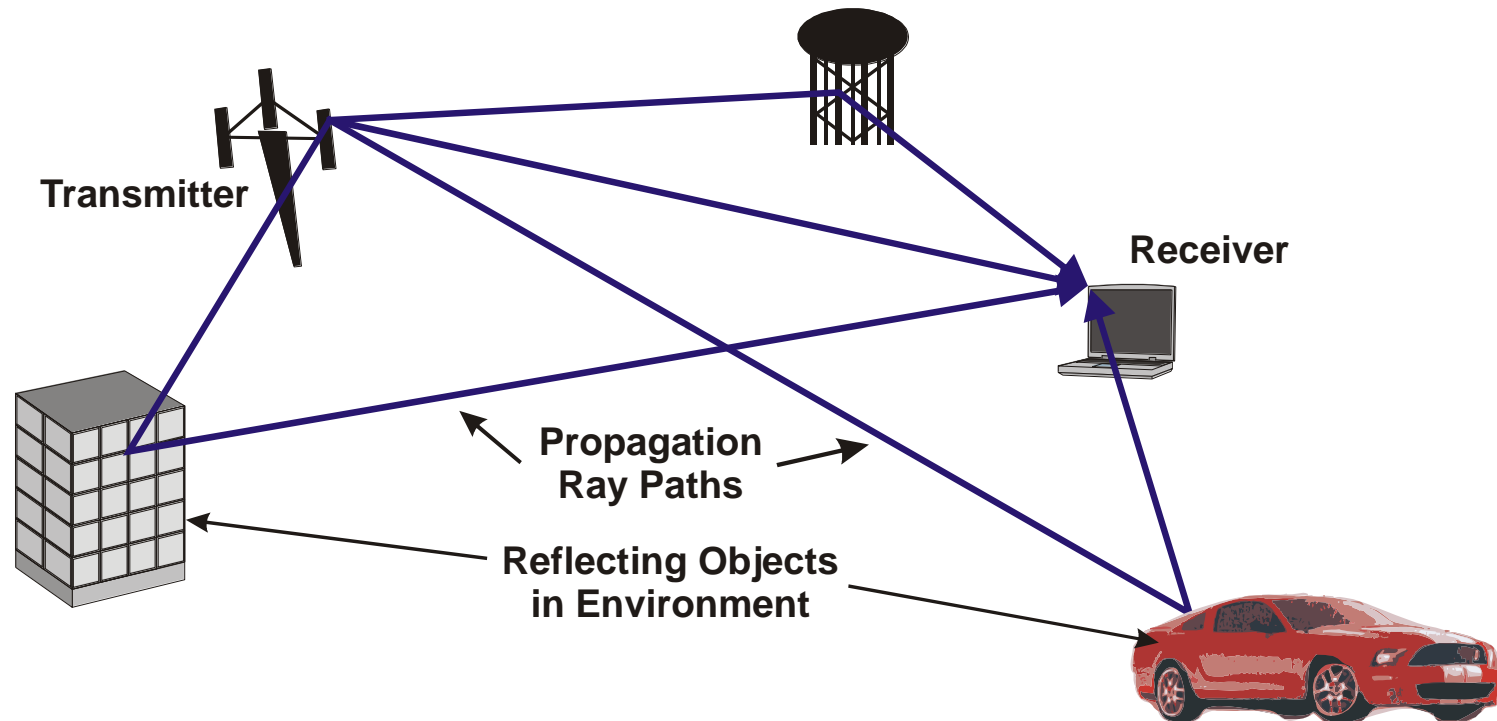

Understanding the Channel Model

- Signal paths are often classified as Line-of-Sight (LOS) and Non-Line-of-Sight (NLOS).

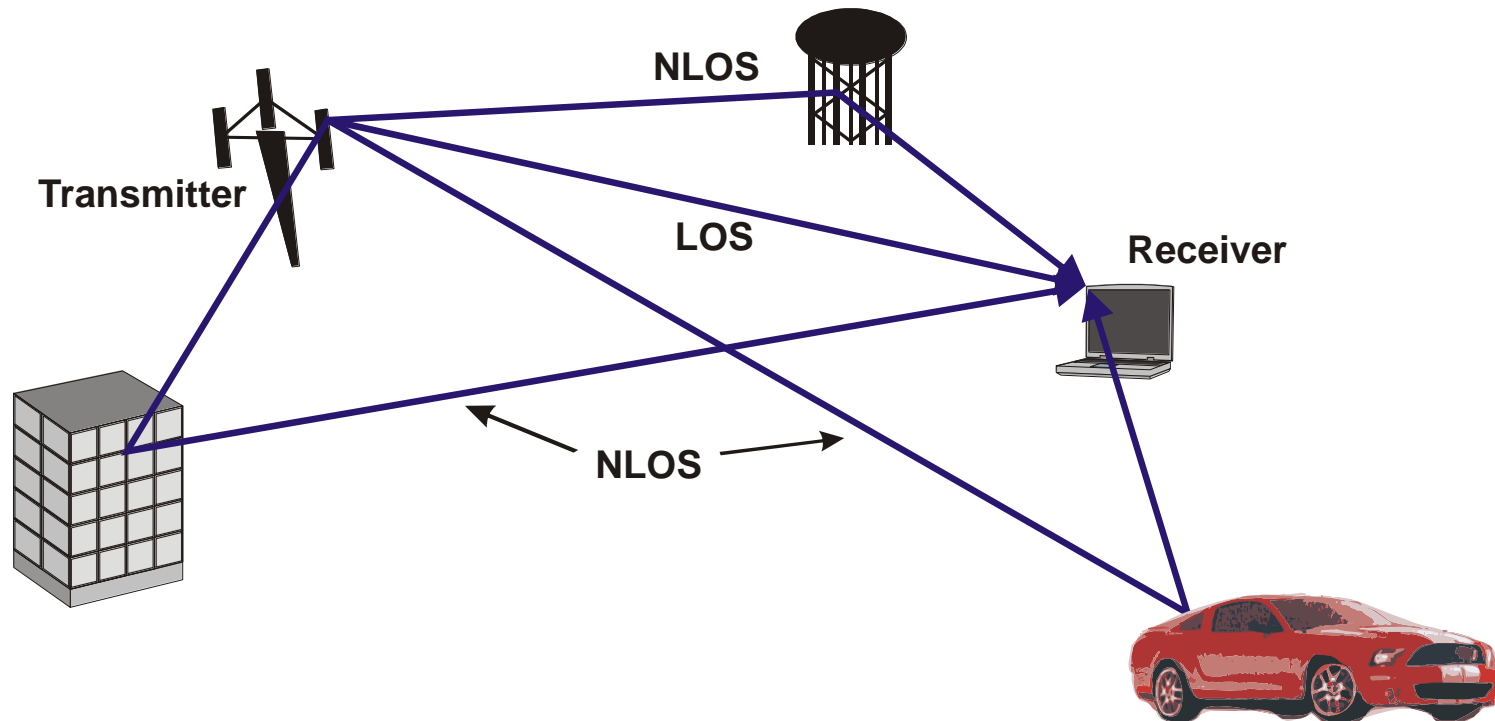

Understanding the Channel Model

- Each path has a different length (propagation delay).

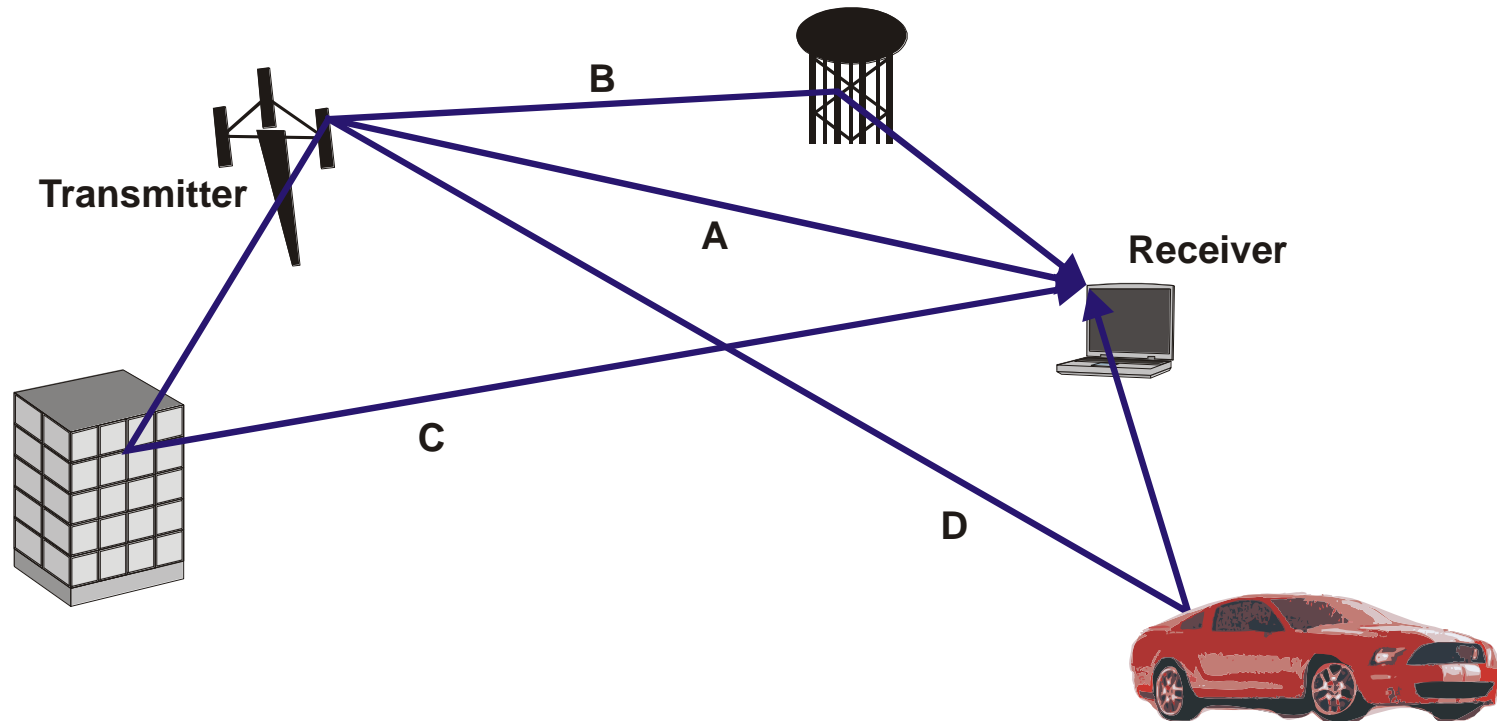

Understanding the Channel Model

- Plotting the signal strength vs. time gives a *power delay profile (PDP)* for the model.

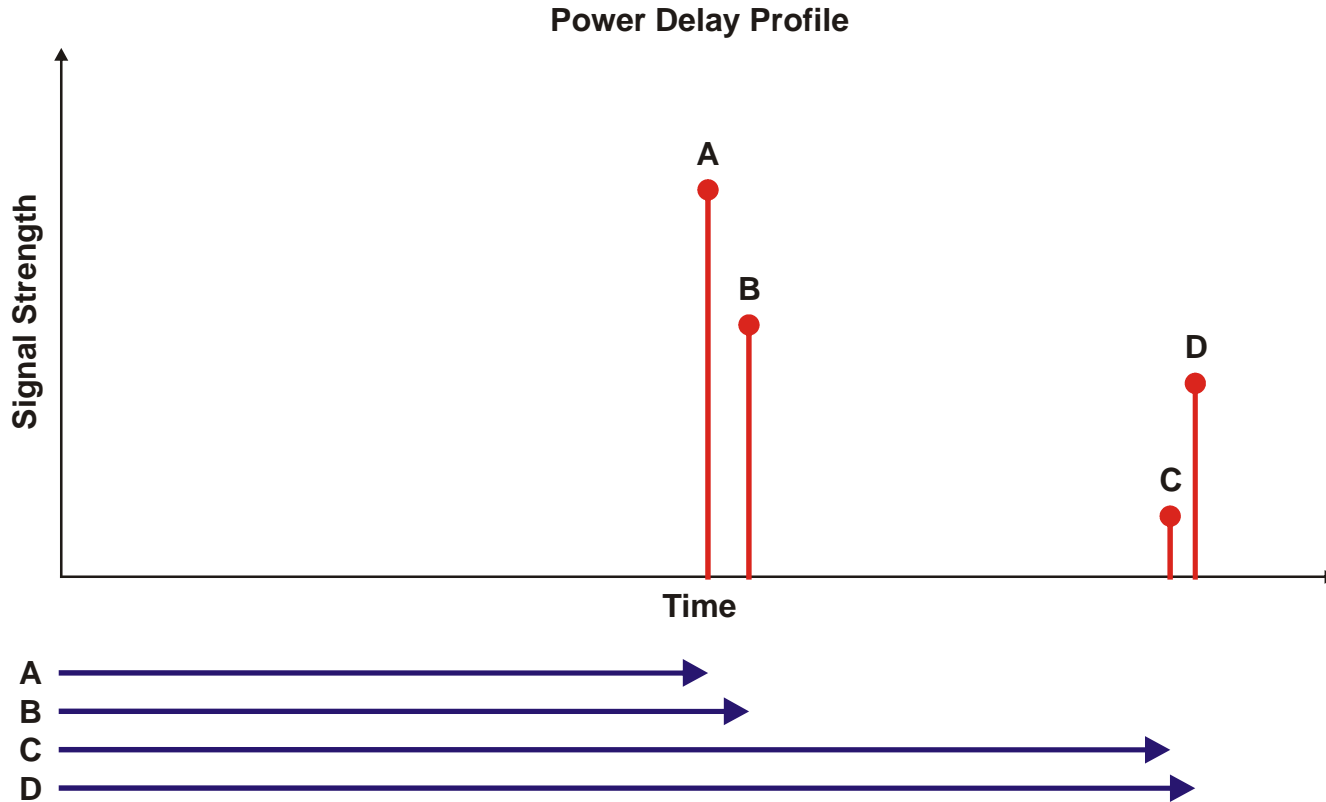

Understanding the Channel Model

- The individual times of arrival are called *taps*, drawing from the concept of a tapped delay line.

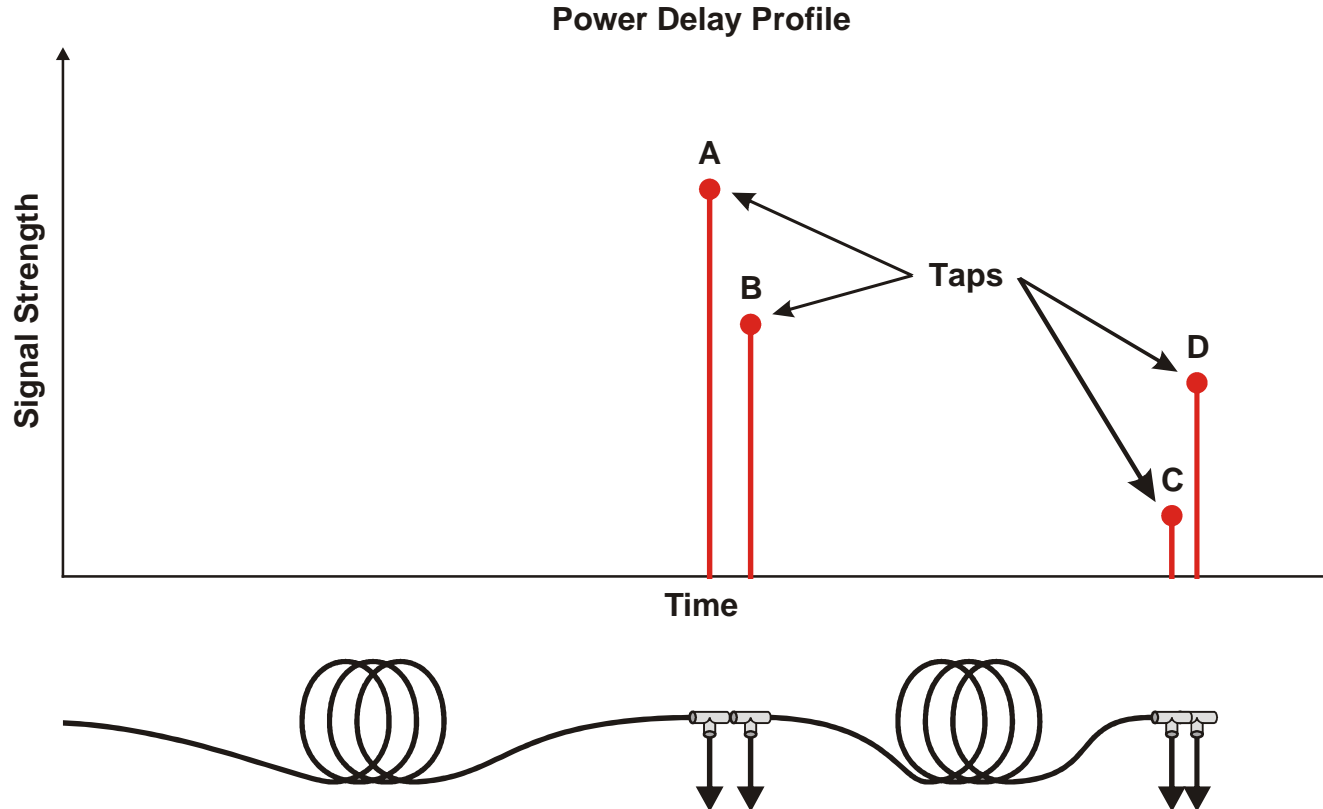

Understanding the Channel Model

- Reflecting objects typically don't just cause one reflected signal.
- Instead, *scatterers* produce a *cluster* of reflections with slightly different delays and varied magnitude and phase.

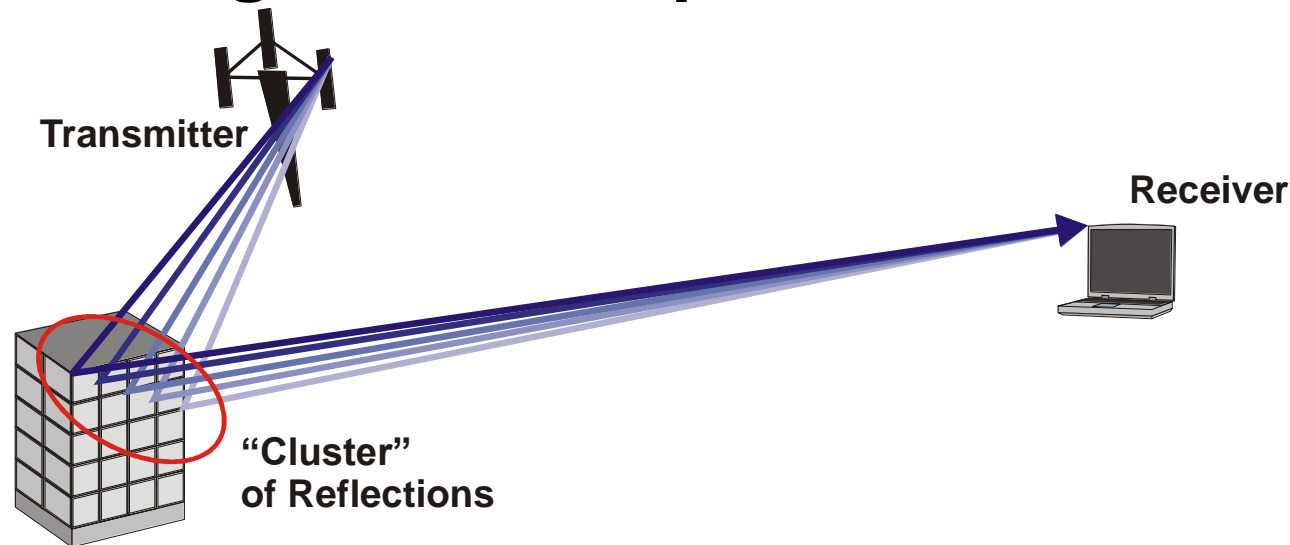

Understanding the Channel Model

- Each cluster produces its own unique statistical PDP.

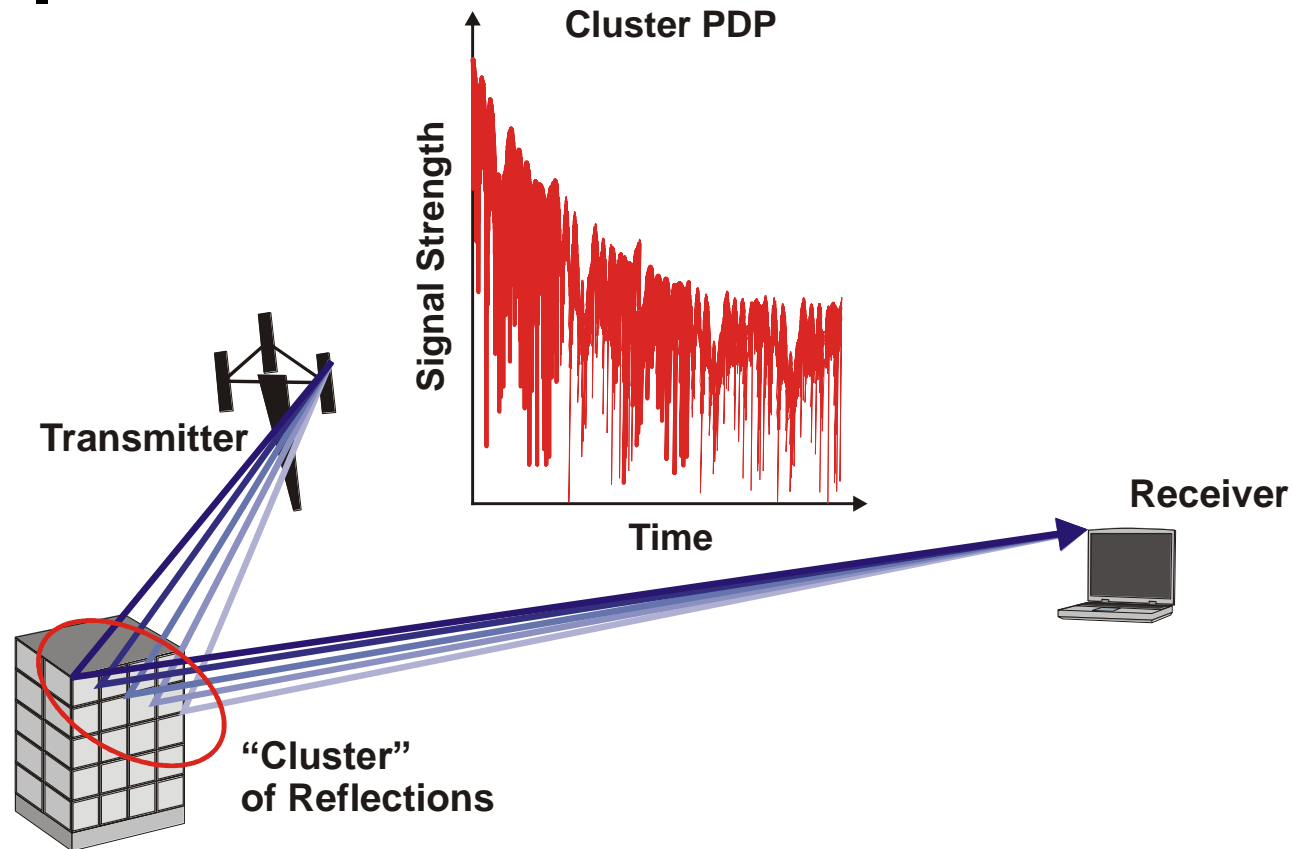

Understanding the Channel Model

- Combining the cluster concept with the tap concept produces realistic time domain profiles.

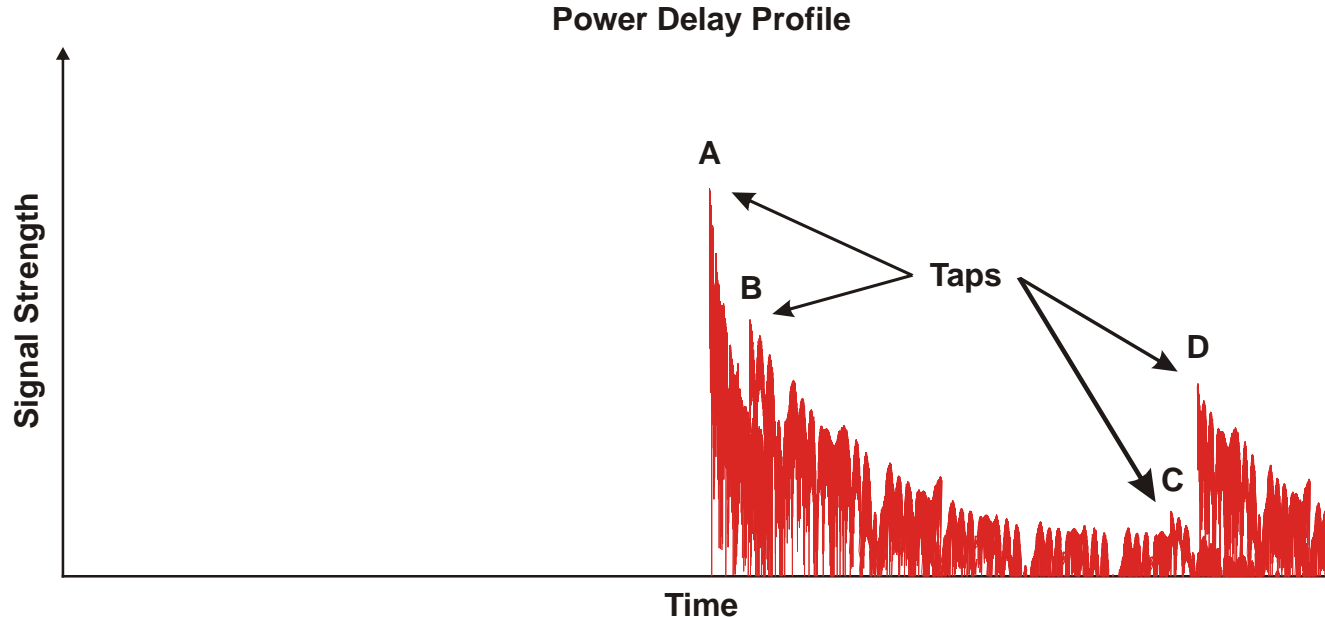

Understanding the Channel Model

- Now the modeled data looks a lot like real measured time domain data acquired using a vector network analyzer.

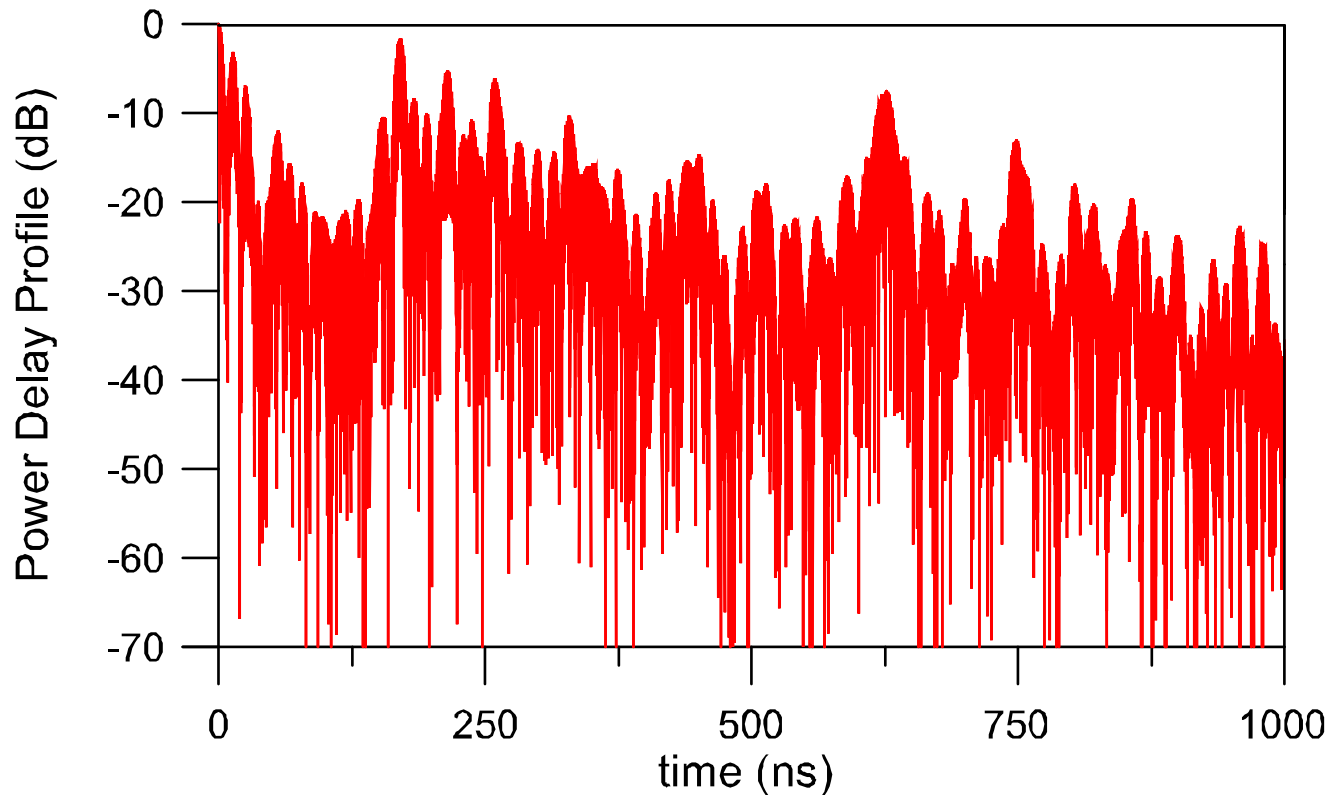

Understanding the Channel Model

- Motion of the transmitter, receiver, or other objects within the environment causes *Doppler shift* of the frequency.

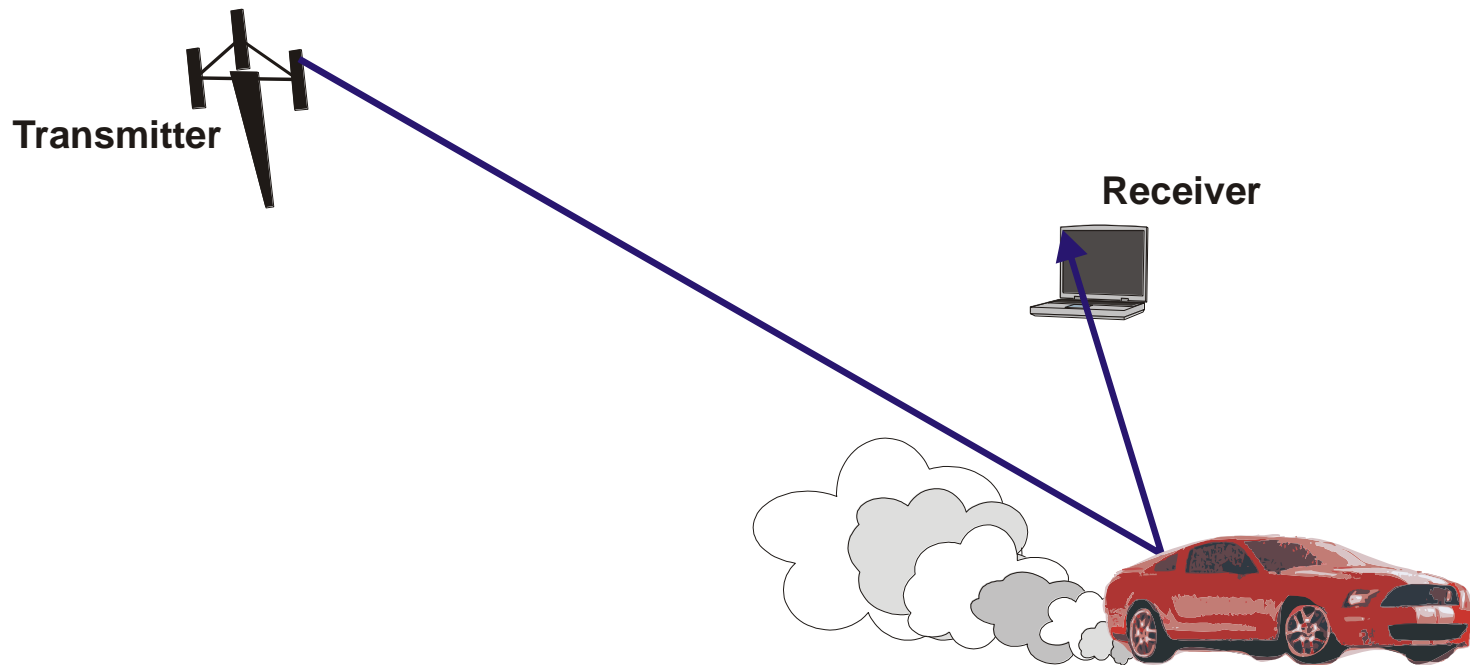

Understanding the Channel Model

- Moving towards a wave increases its frequency, while moving away decreases the frequency.

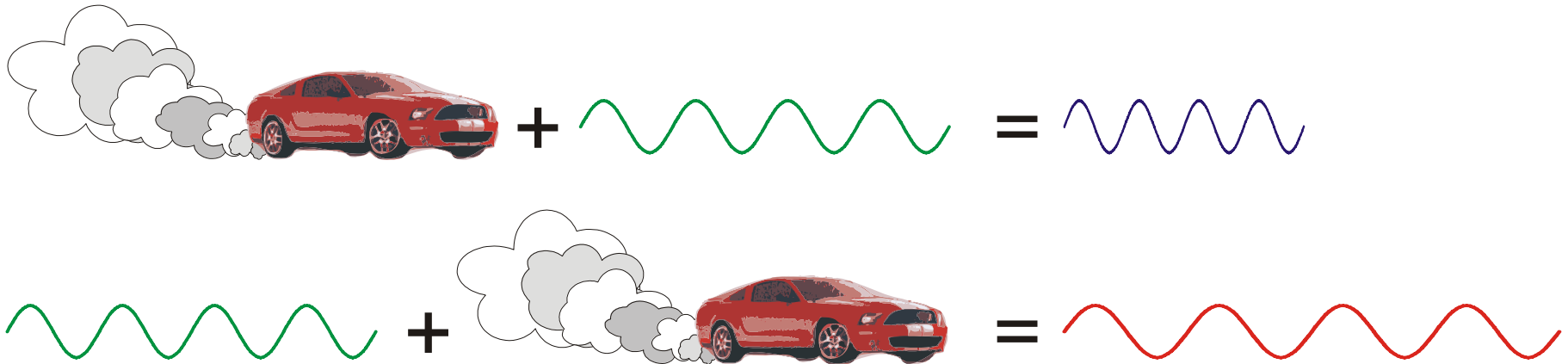

- A moving radio results in *Doppler spread* since it moves towards some reflections and away from others.

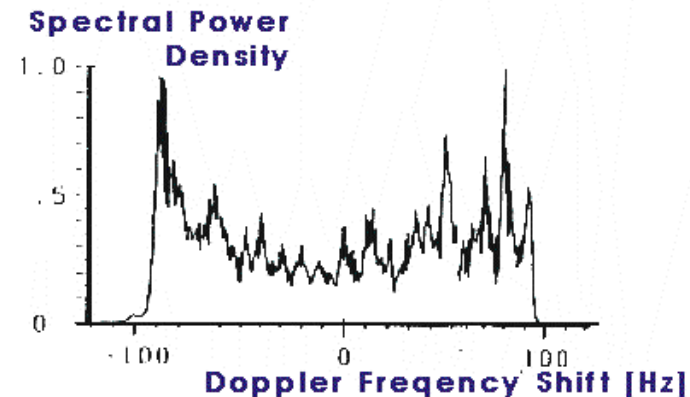

Understanding the Channel Model

- ***Spatial channel models*** include geometric information about the location of scatterers, and determine channel behavior based on *angles of departure and arrival (AOD/AOA)* and the *angular spread* for each cluster.

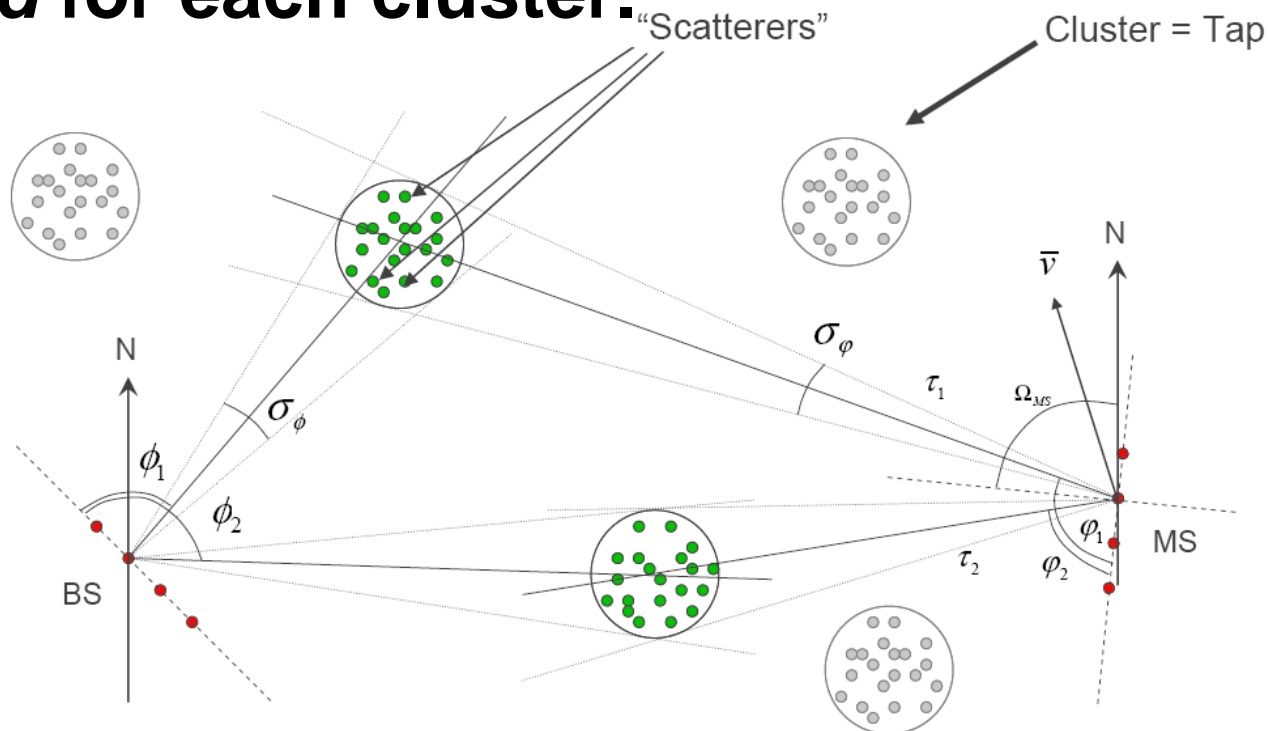

Understanding the Channel Model

- **Spatial channel models for conducted testing also apply assumed antenna patterns for the source and receiver.**

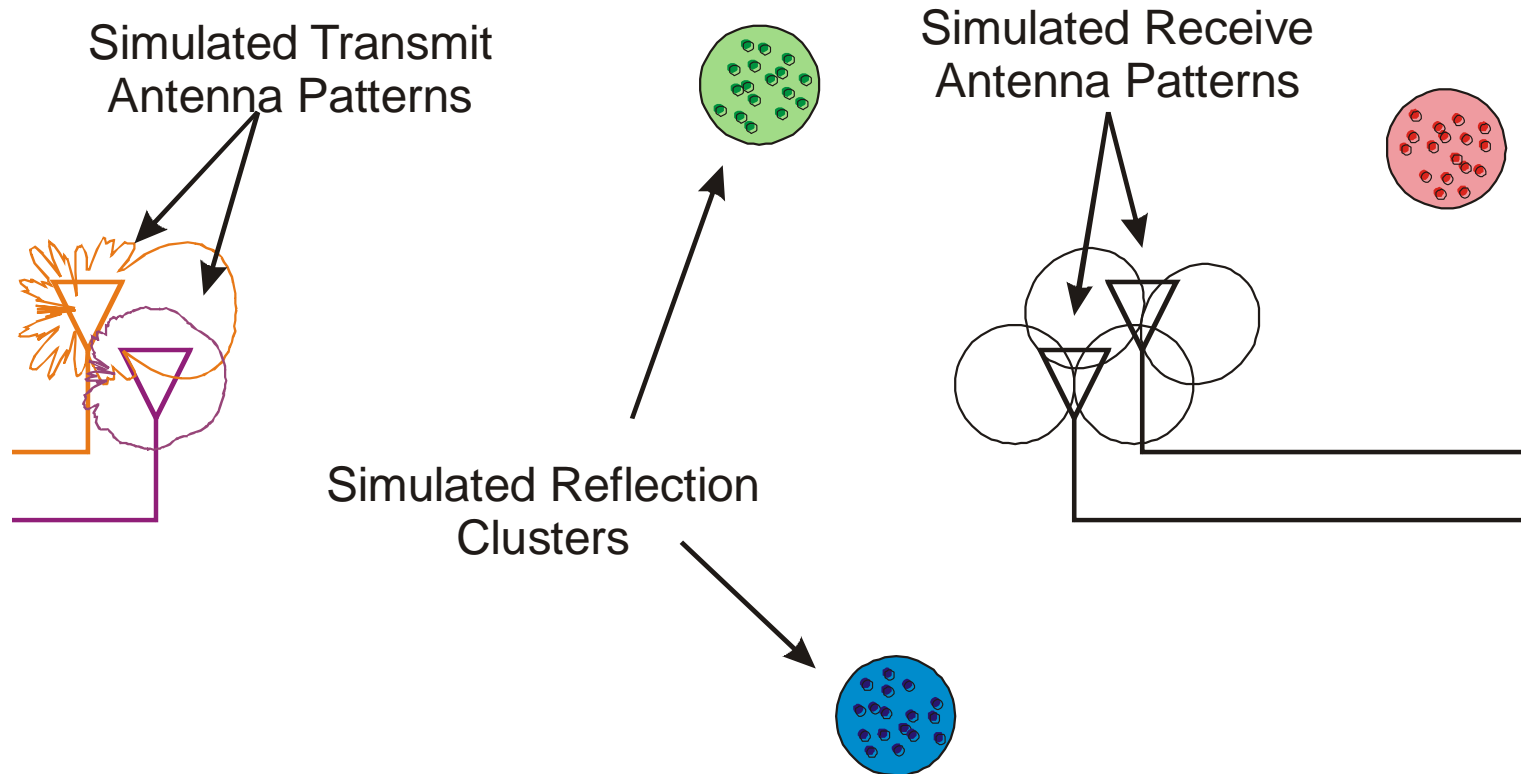

Implications of OTA Testing

- A primary goal of OTA testing is to determine radio performance of the DUT with the actual antenna patterns, orientation, and spacing.
- If this was all that was required, a combination of antenna pattern measurement and conducted channel modeling would suffice.
- However, traditional OTA measurements of TRP/TIS perform simultaneous evaluation of the entire RF signal chain for a variety of reasons:

Implications of OTA Testing

- **Platform Desensitization – interference from platform components enters radio through attached antennas.**

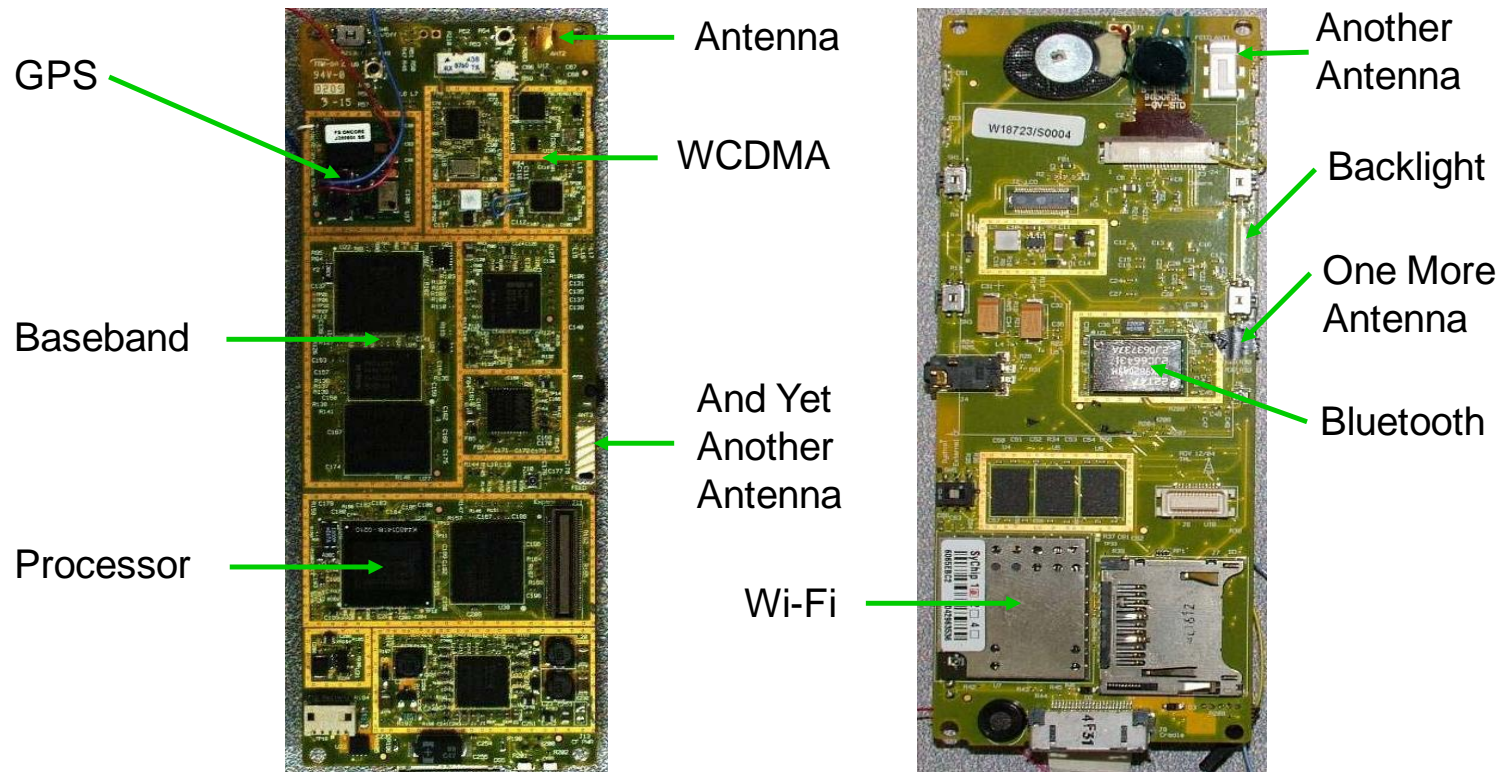

Implications of OTA Testing

- **Near Field Influences – including platform structure, head, hands, body, table top, etc.**



Implications of OTA Testing

- **Mismatch and other Interaction Factors – performance of a radio into a matched 50 Ohm load may not be the same as that into a mismatched or detuned antenna, resulting in non-linear behavior.**
- **Antenna-Antenna Interactions – mutual coupling of antennas may not be accounted for properly in pattern tests.**
- **Cable Effects – currents on feed cables can alter the radiation pattern, especially for small DUTs.**

Spatial Environment Simulation

- **MIMO relies on a complex multipath environment to provide the information necessary to reconstruct multiple source signals that have been combined into multiple receive signals.**

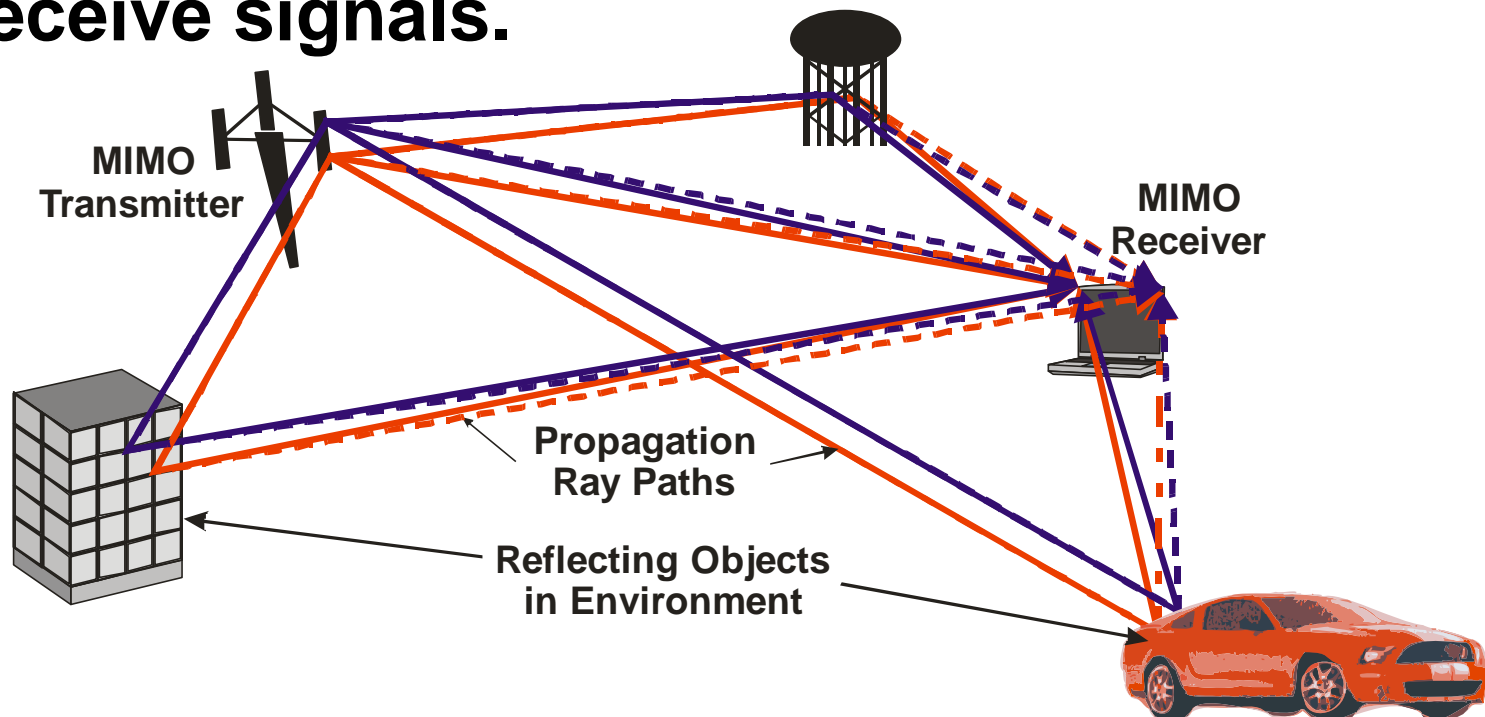

Spatial Environment Simulation

- The goal of the OTA Environment Simulator is to place the DUT in a controlled, isolated near field environment and then simulate everything outside that region.

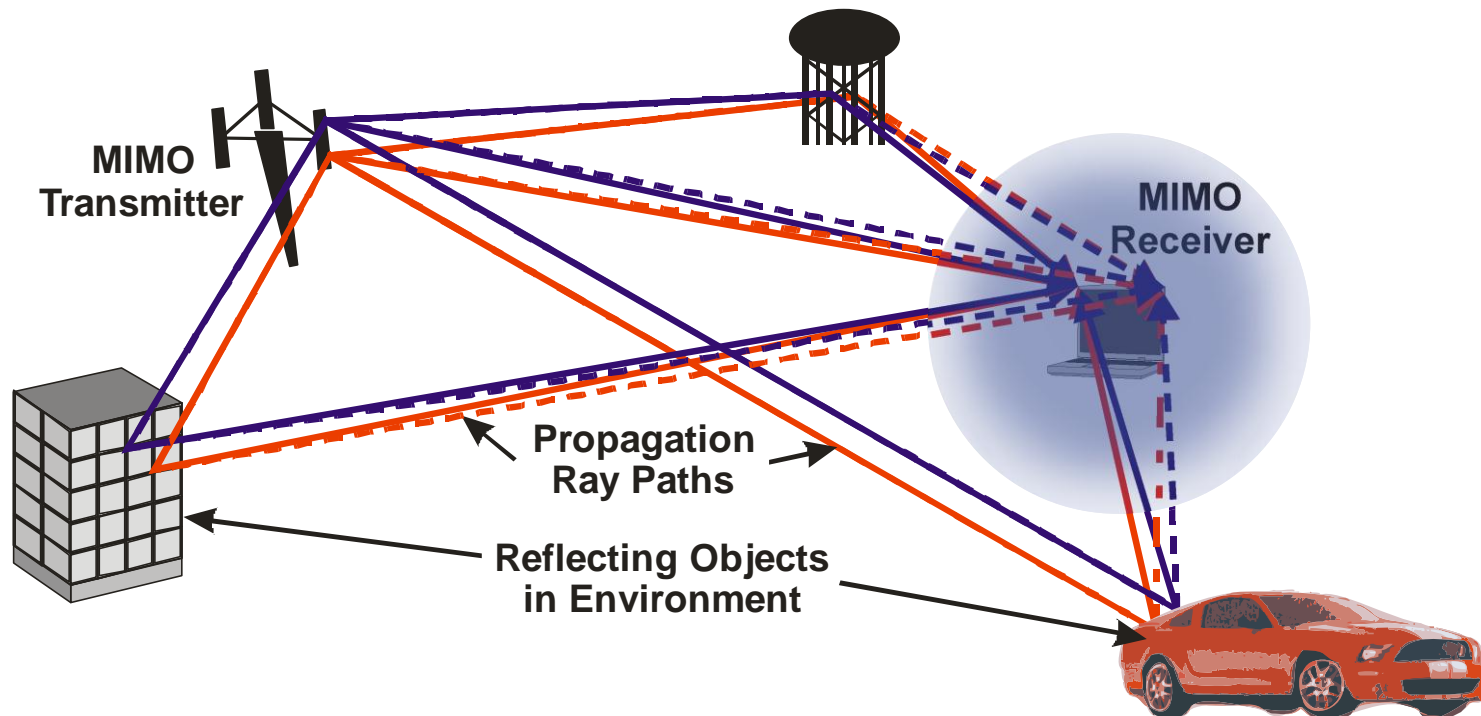

Spatial Environment Simulation



Spatial Environment Simulation



Spatial Environment Simulation

- From inside the bubble, everything looks the same, even though everything outside the bubble is simulated.



Spatial Environment Simulation

- Practical limitations may result in a low resolution picture of the environment.
- Using active spatial channel emulation provides motion simulation, etc.



Spatial Environment Simulation

- We may also only care about a portion of the environment.
 - E.g. Most reflections cluster near the horizon.



Spatial Environment Simulation

- For comparison, using a reverberation chamber averages out the spatial picture. The same (statistical) signal comes from all directions.



Spatial Environment Simulation

- The alternate two antenna method proposed is a less accurate representation of the real environment.

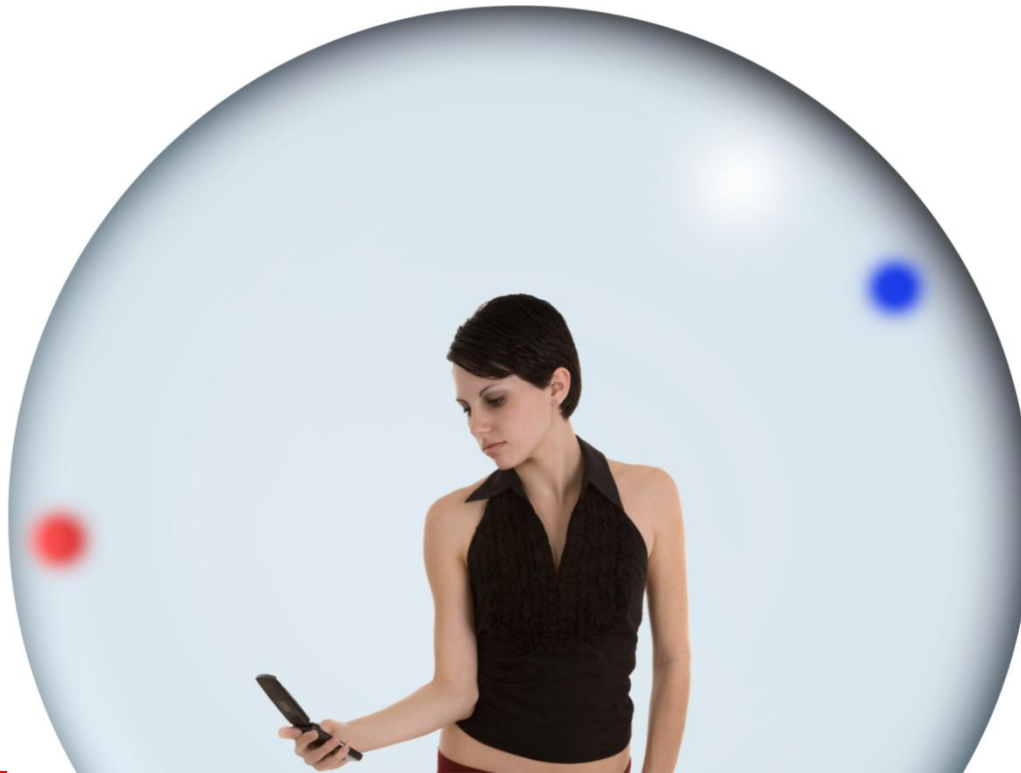

Spatial Environment Simulation

- The two stage method uses antenna pattern data applied to a conducted channel emulation model.



Spatial Environment Simulation

- **Example: Typical Multi-Path Power Delay Profile from a Real World Environment**

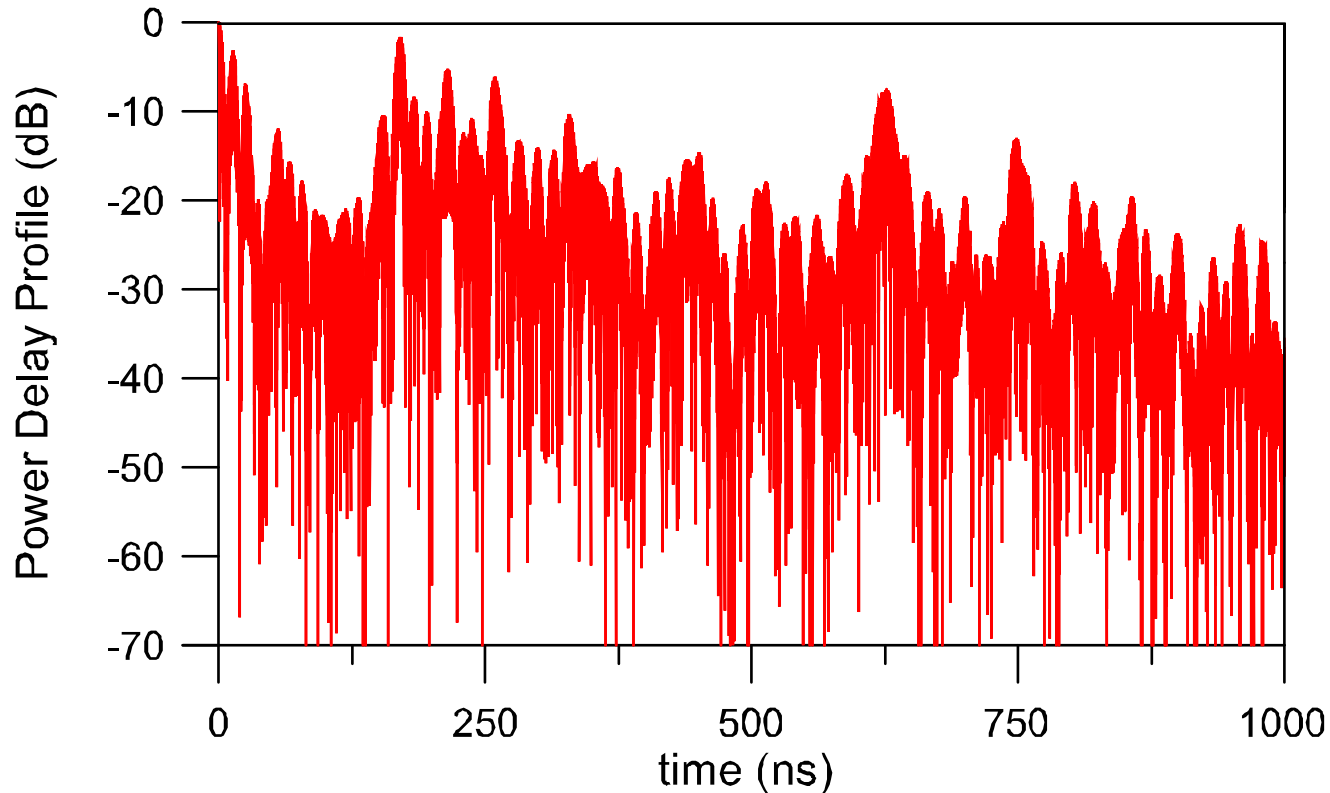

Spatial Environment Simulation

- Using a fully anechoic chamber to isolate the DUT, a matrix of antennas arrayed around the DUT can be used to produce different angles of arrival (AOA).

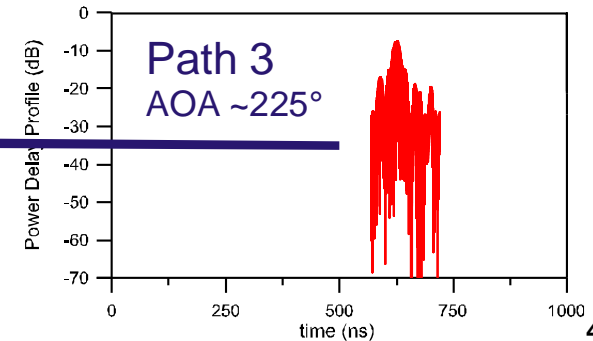
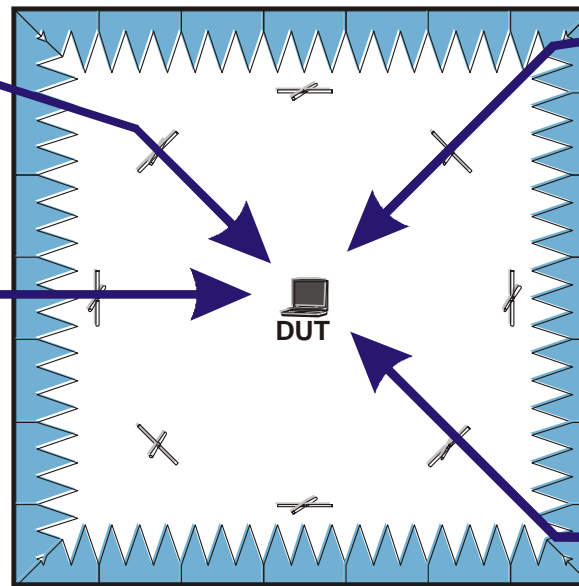
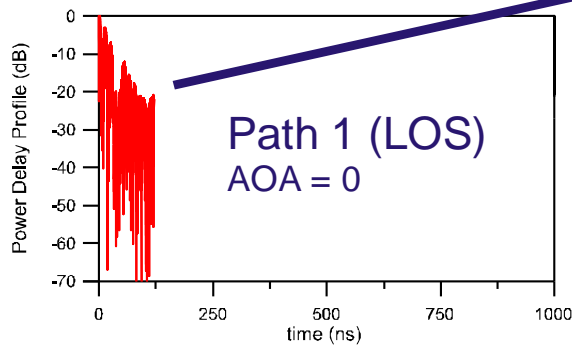
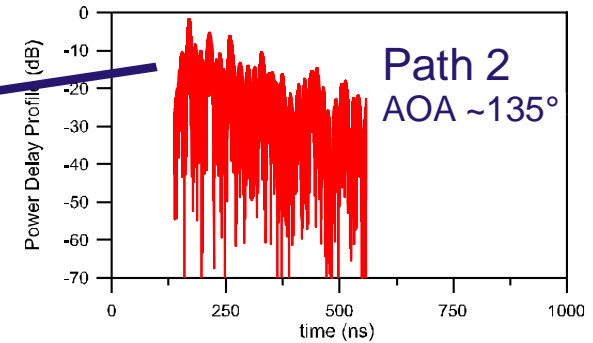
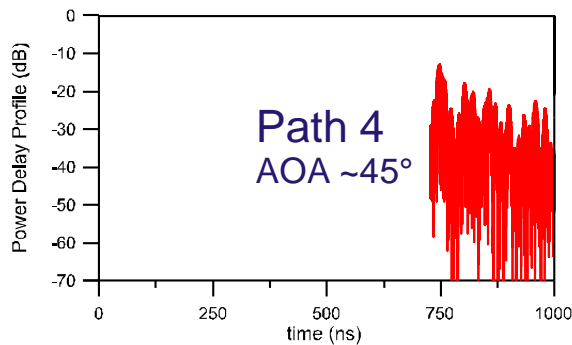

Spatial Environment Simulation

- A spatial channel emulator (a channel emulator with modified channel models) simulates the desired external environment between BSE and DUT.

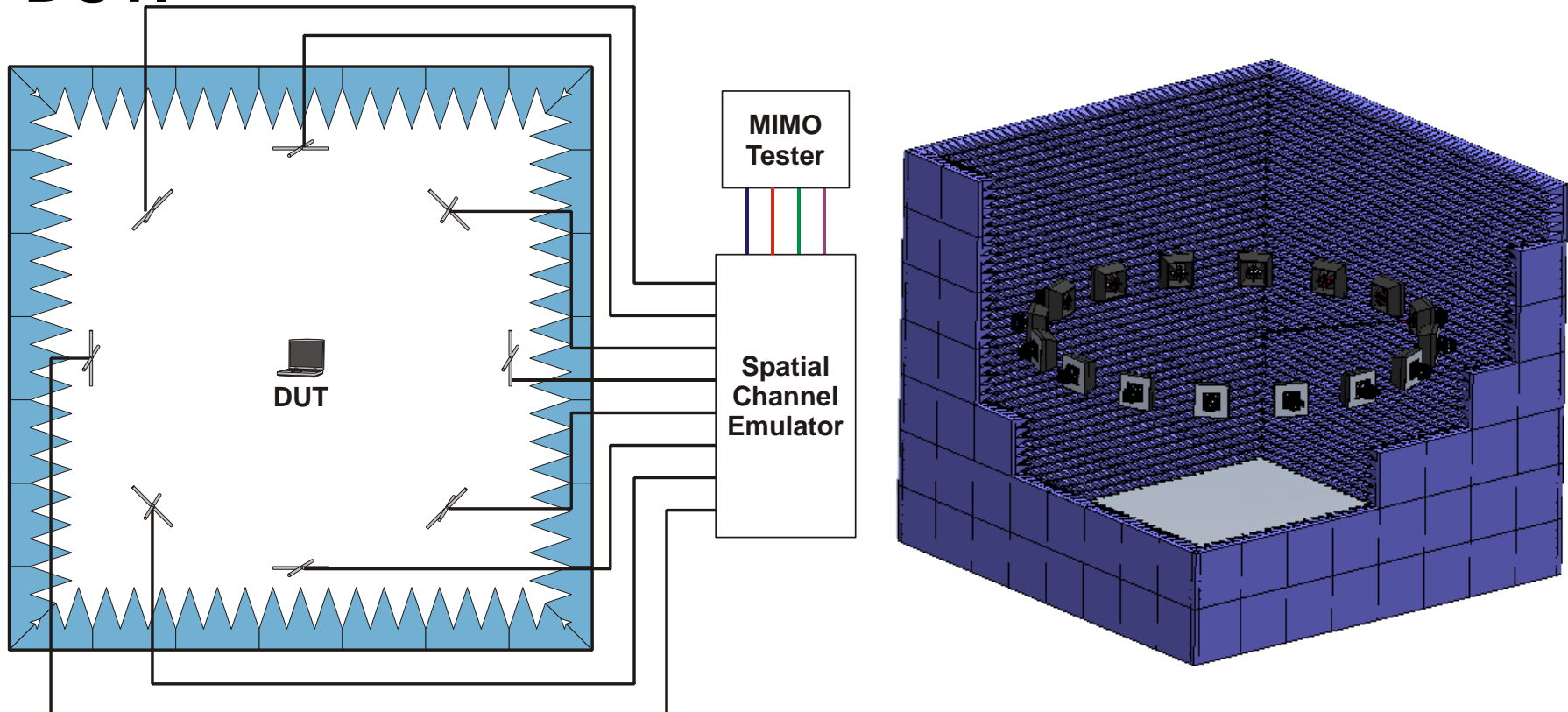

Spatial Environment Simulation

- **Evaluation of SIMO functions like beam forming and receive diversity likely require only rudimentary environment simulation.**
 - Sufficient to simulate only basic directional effects and spatial fading.
- **While there are a variety of simplistic ways to create an external environment containing delay spread, fading, and even repeatable reflection “taps”, they may be insufficient for proper evaluation of MIMO performance.**

Spatial Environment Simulation

- Spatial channel models include clusters of scatterers with each tap having an angular spread as well as a delay spread.

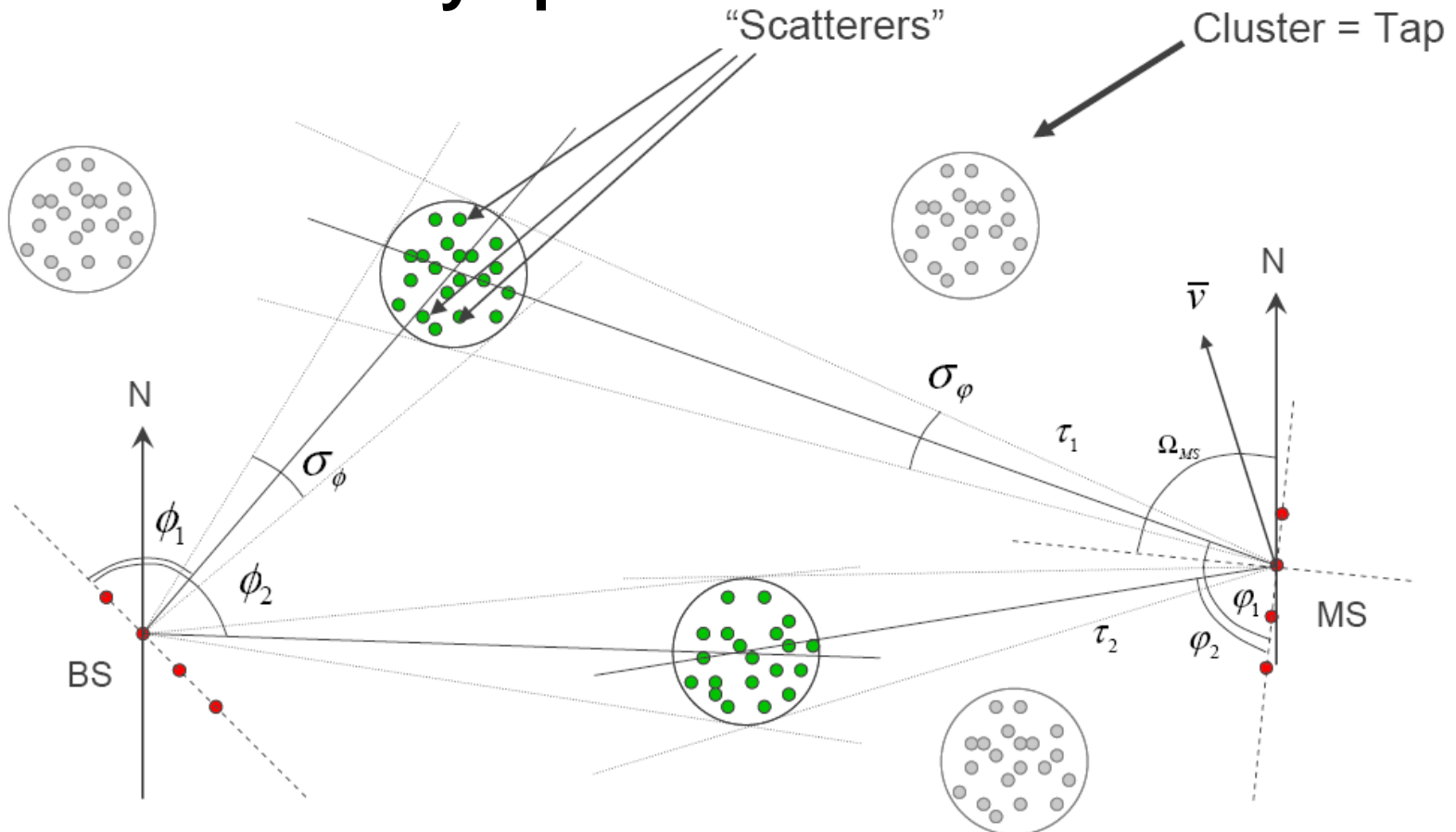

Designing the OTA Environment Simulator

- The angular spread of a given cluster is simulated by feeding multiple antennas with an appropriate statistical distribution of the source signal.

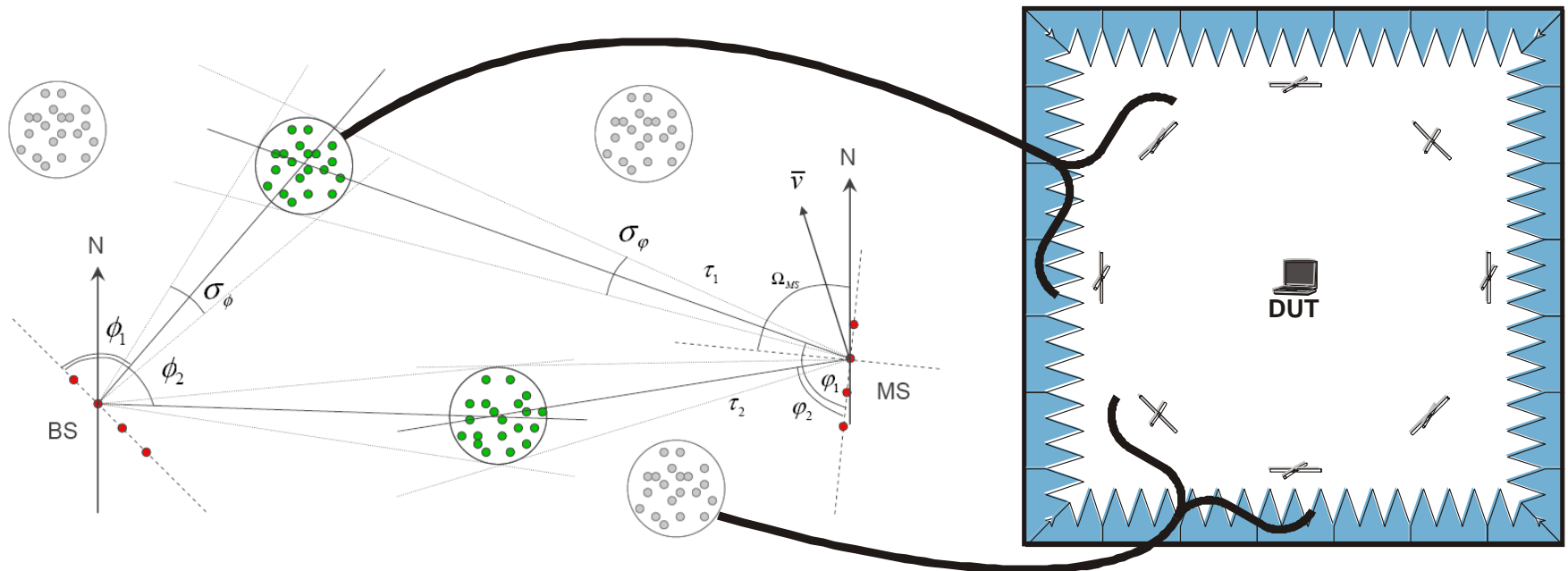

Spatial Environment Simulation

- **Converting a conducted channel model to an OTA channel model:**
 - Conducted model simulates TX and RX antennas.

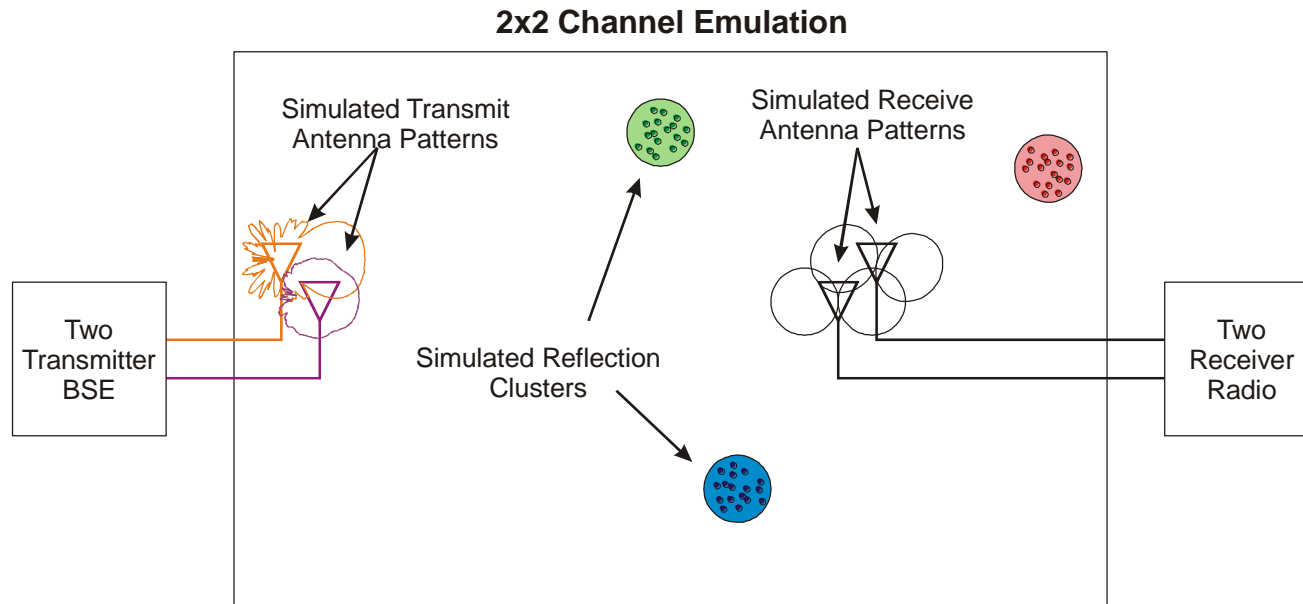

Spatial Environment Simulation

■ Conducted channel model:

- Ray paths from reflections in simulated environment are collected at each simulated receive antenna.

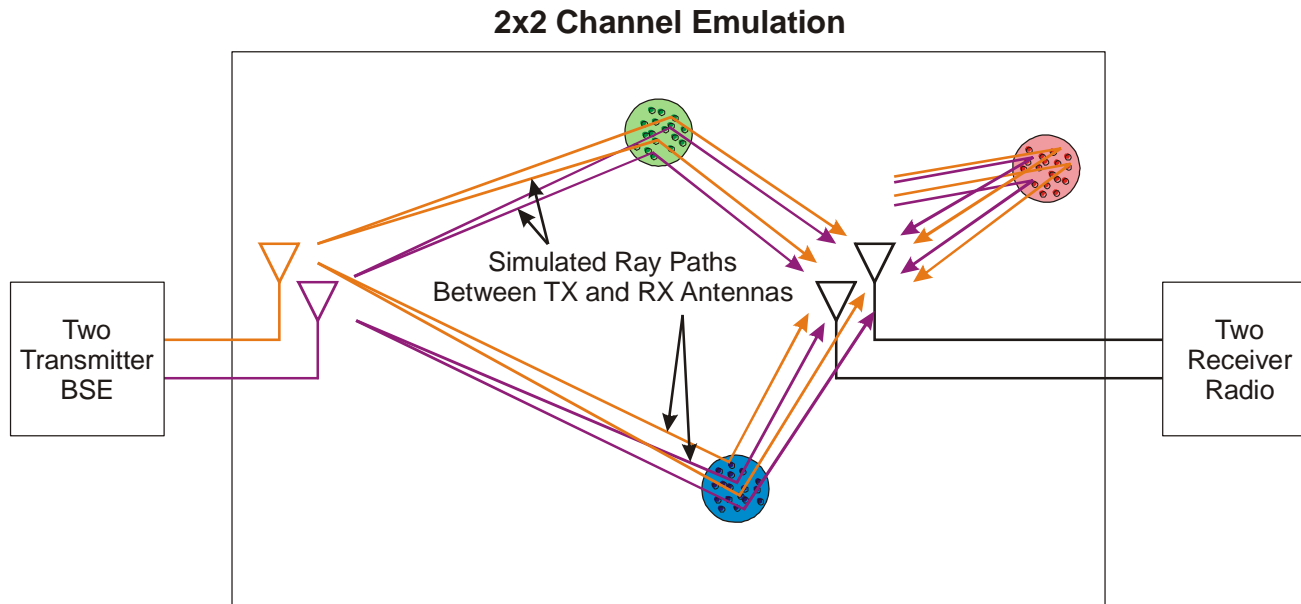

Spatial Environment Simulation

- **Converting a conducted channel model to an OTA channel model:**
 - Clusters produced different angles of arrival (AOA)

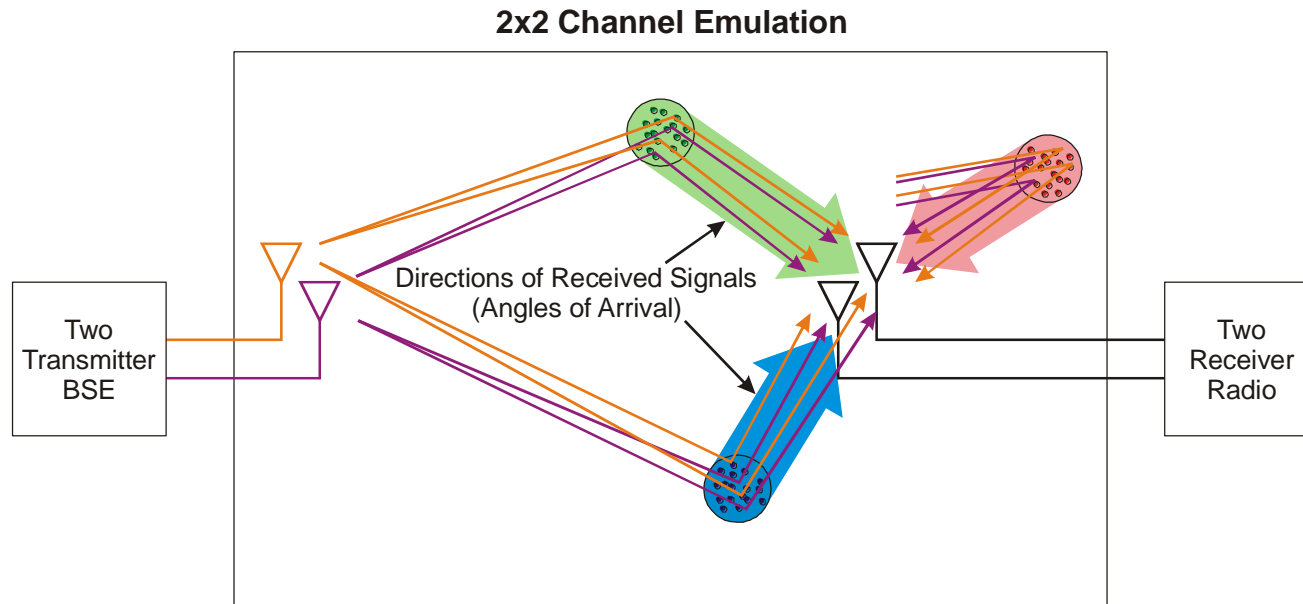

Spatial Environment Simulation

- **Converting a conducted channel model to an OTA channel model:**
 - Grouping AOAs, we can remove virtual RX antennas.

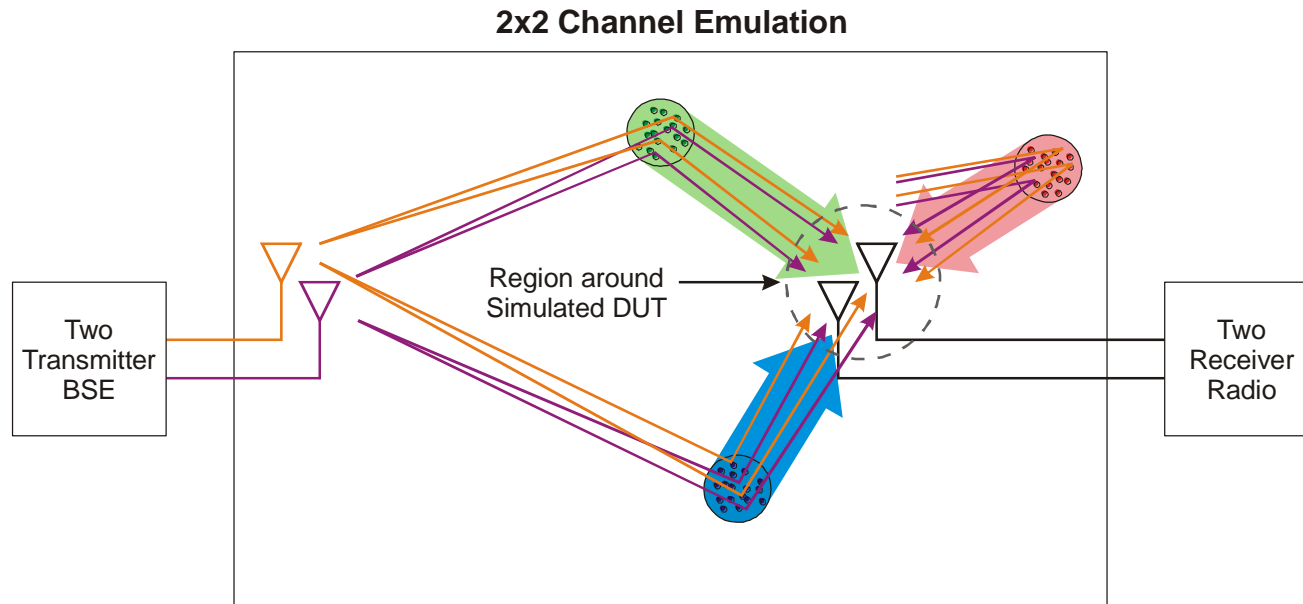

Spatial Environment Simulation

■ OTA channel model:

- 2xN channel emulator used to feed N antennas for AOA simulation around DUT with real antennas.

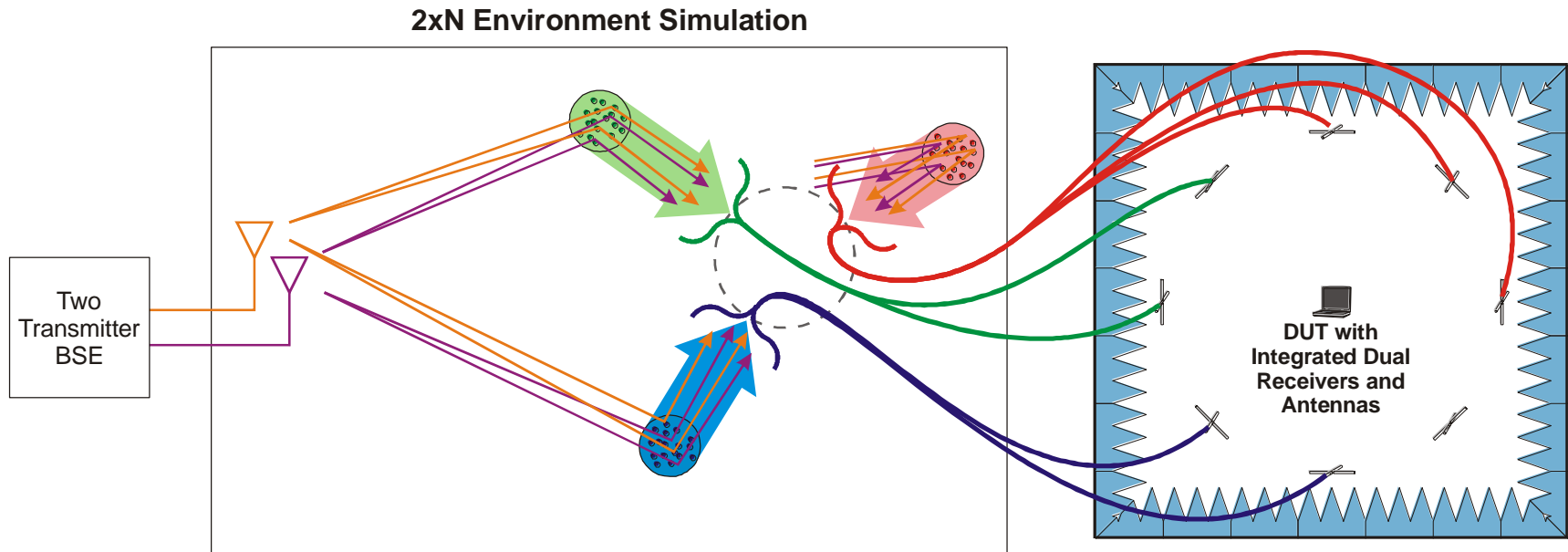

Spatial Environment Simulation

- Ideally, the sphere around the DUT would define a perfect boundary condition that exactly reproduces the desired field distribution inside the test region.
- Practicality and physical limitations impose restrictions that create a less than ideal environment simulation.
- The chosen number of antenna positions limits the available range of “Real” propagation directions.
- Splitting clusters across discrete antennas does not produce true plane wave behavior in test region.
 - Results in an interference pattern with wave-like distribution in center of test region.

Spatial Environment Simulation

- **Discretization results in an interference pattern with wave-like distribution in center of test region.**
 - Quality depends on angular spacing and number of antennas used to create interference pattern.

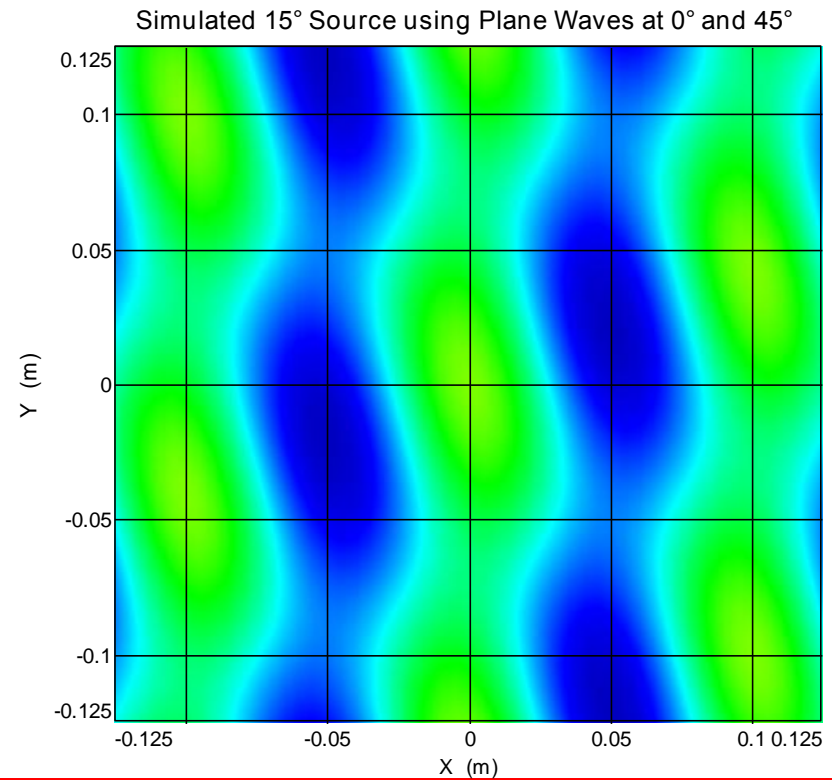
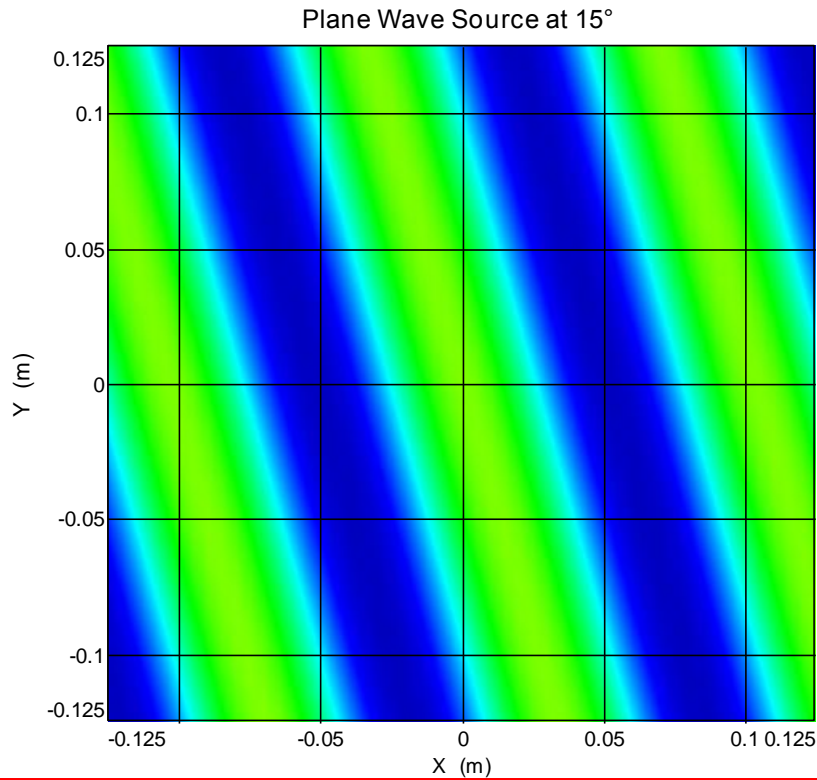

Spatial Environment Simulation

■ Effect of angular resolution on simulated AOA.

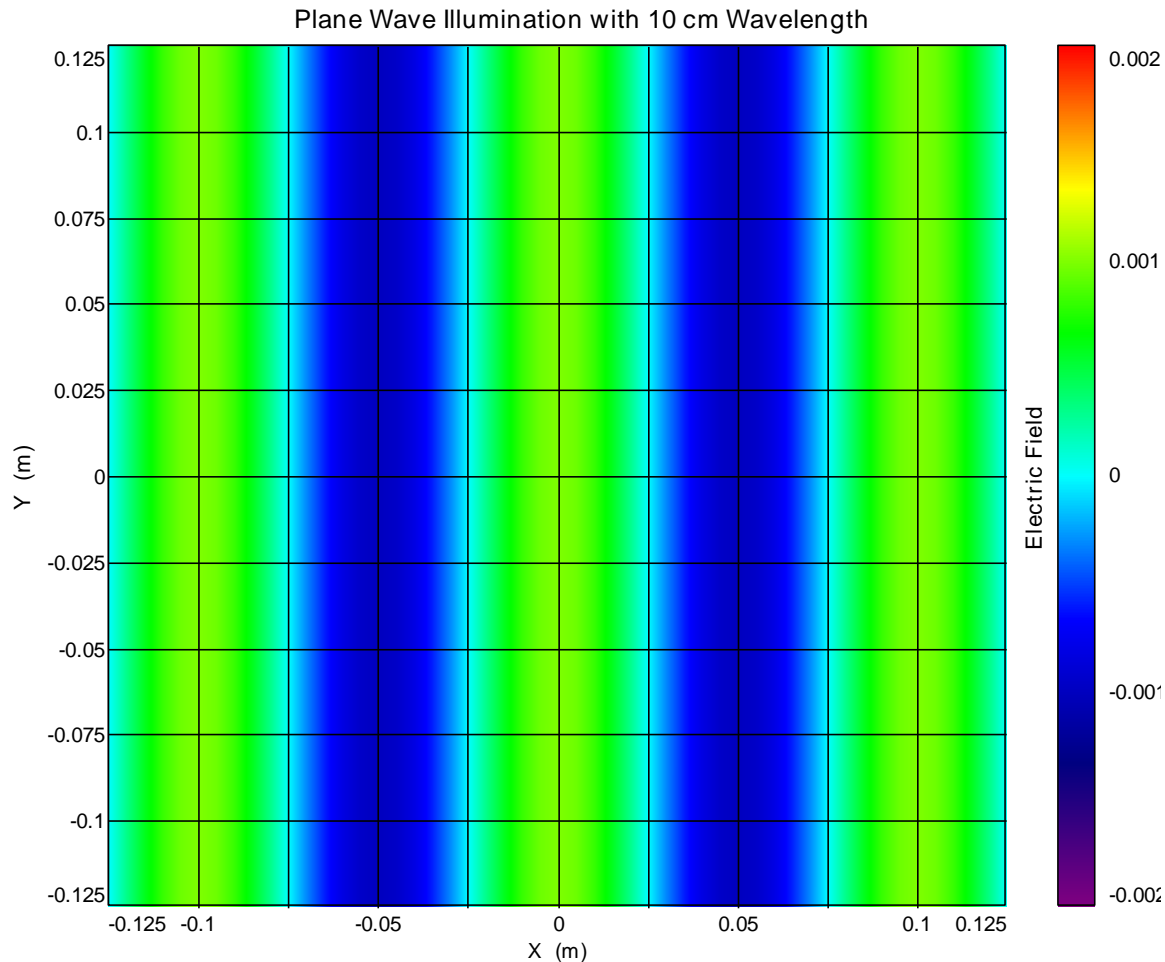

Spatial Environment Simulation

■ Effect of angular resolution on simulated AOA.

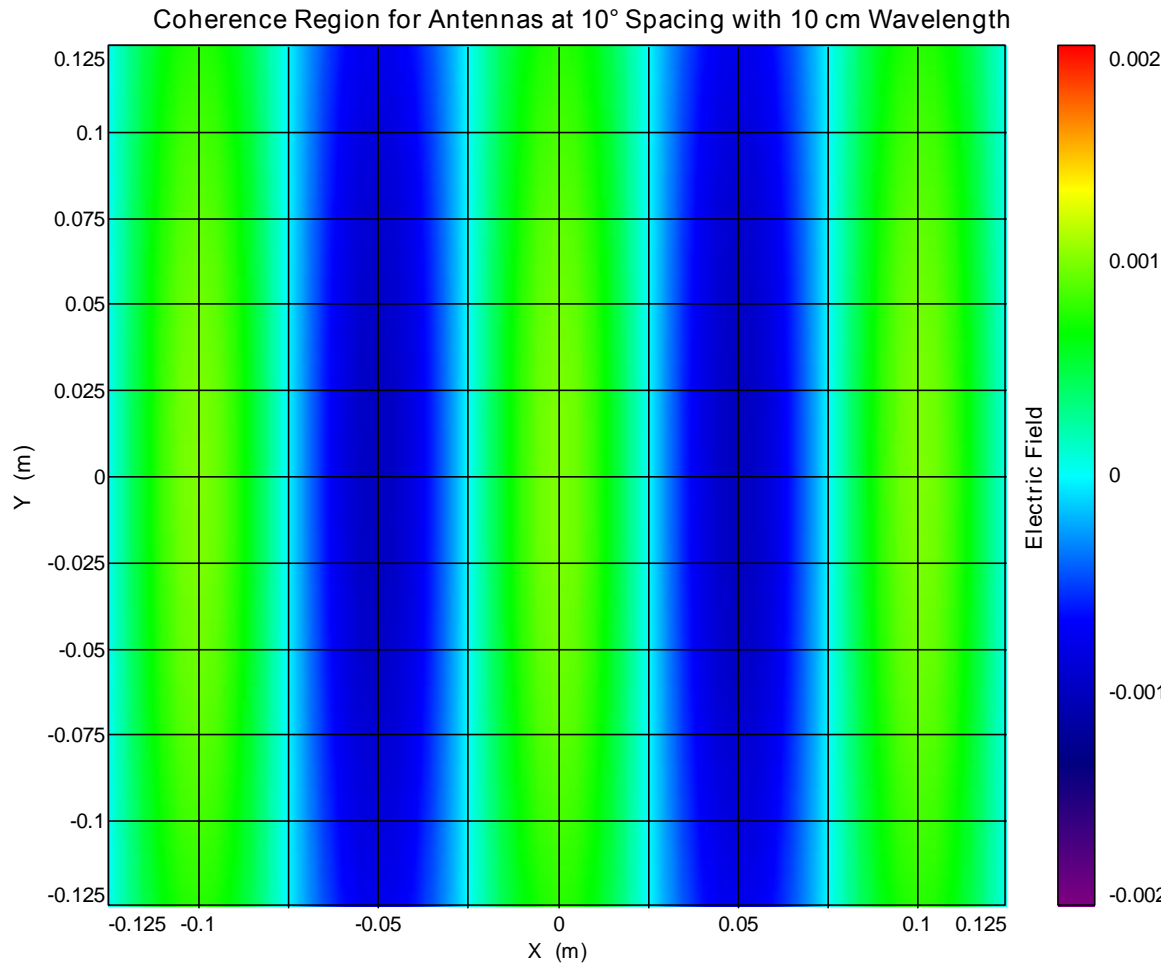

Spatial Environment Simulation

■ Effect of angular resolution on simulated AOA.

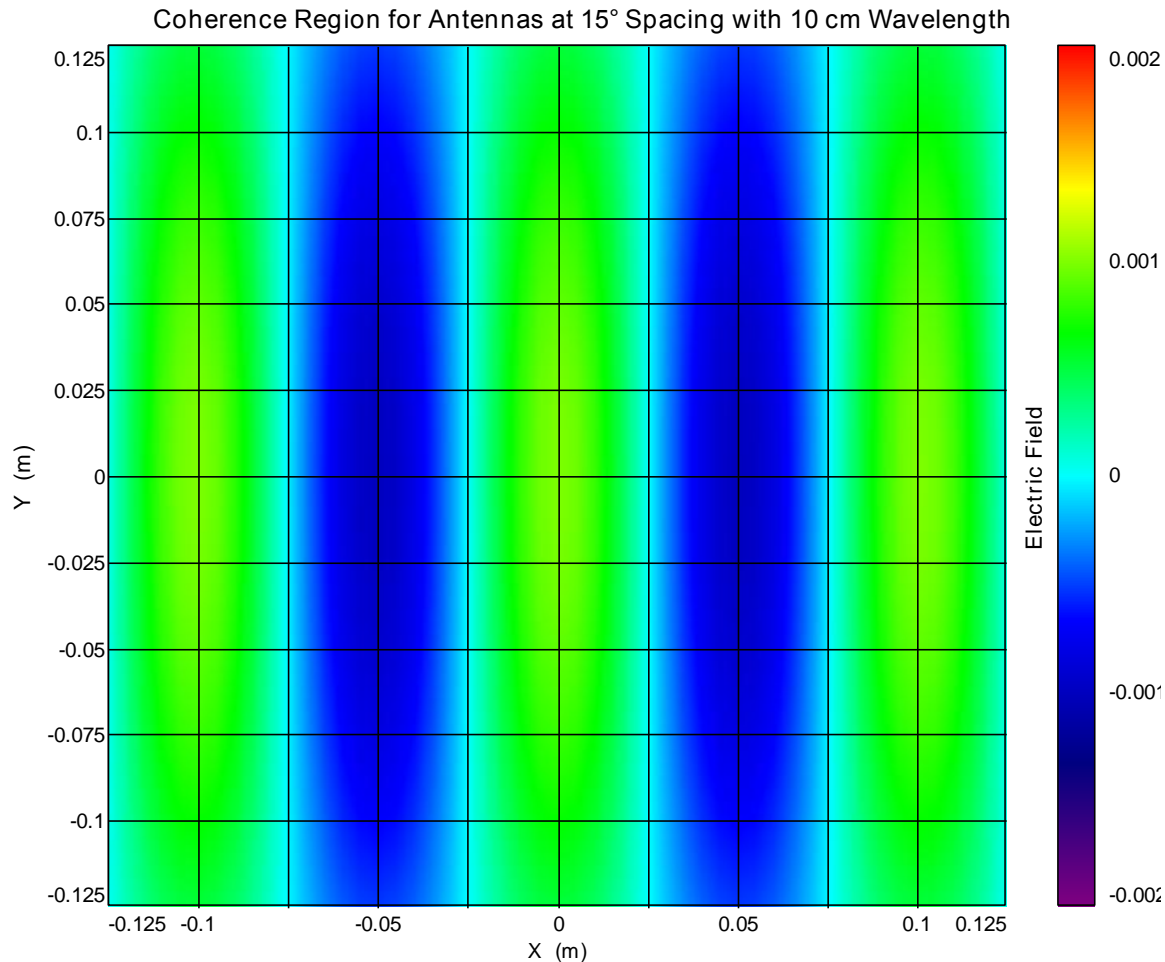

Spatial Environment Simulation

■ Effect of angular resolution on simulated AOA.

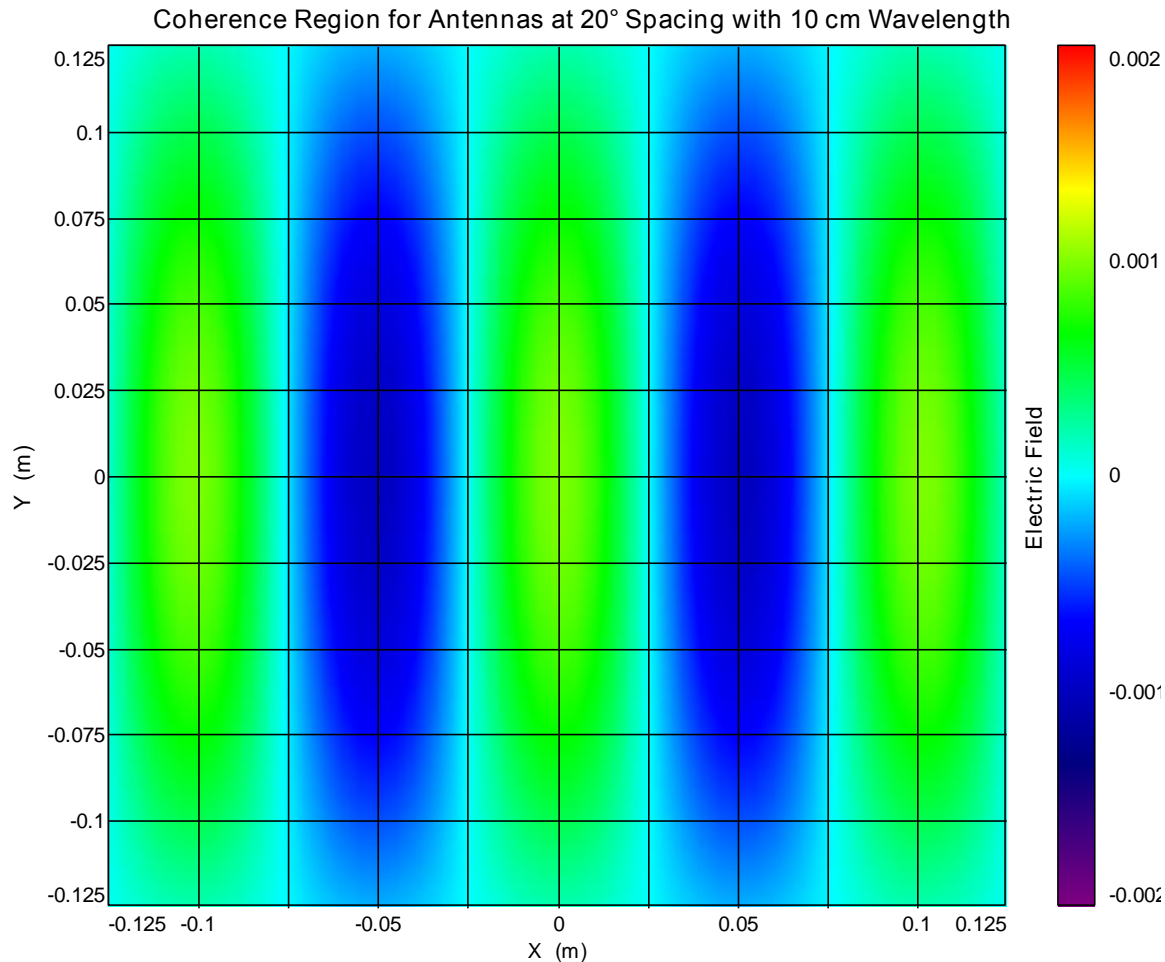

Spatial Environment Simulation

■ Effect of angular resolution on simulated AOA.

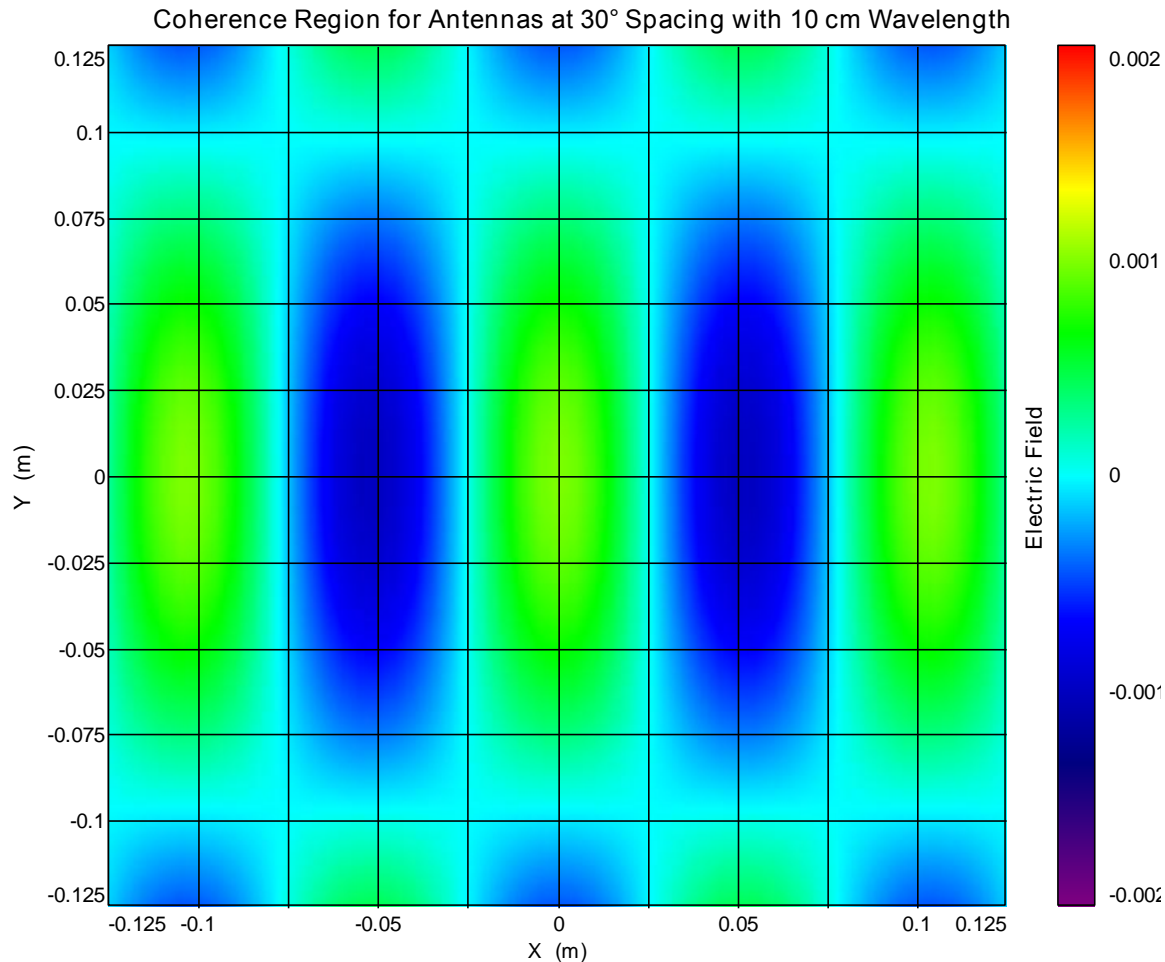

Spatial Environment Simulation

■ Effect of angular resolution on simulated AOA.

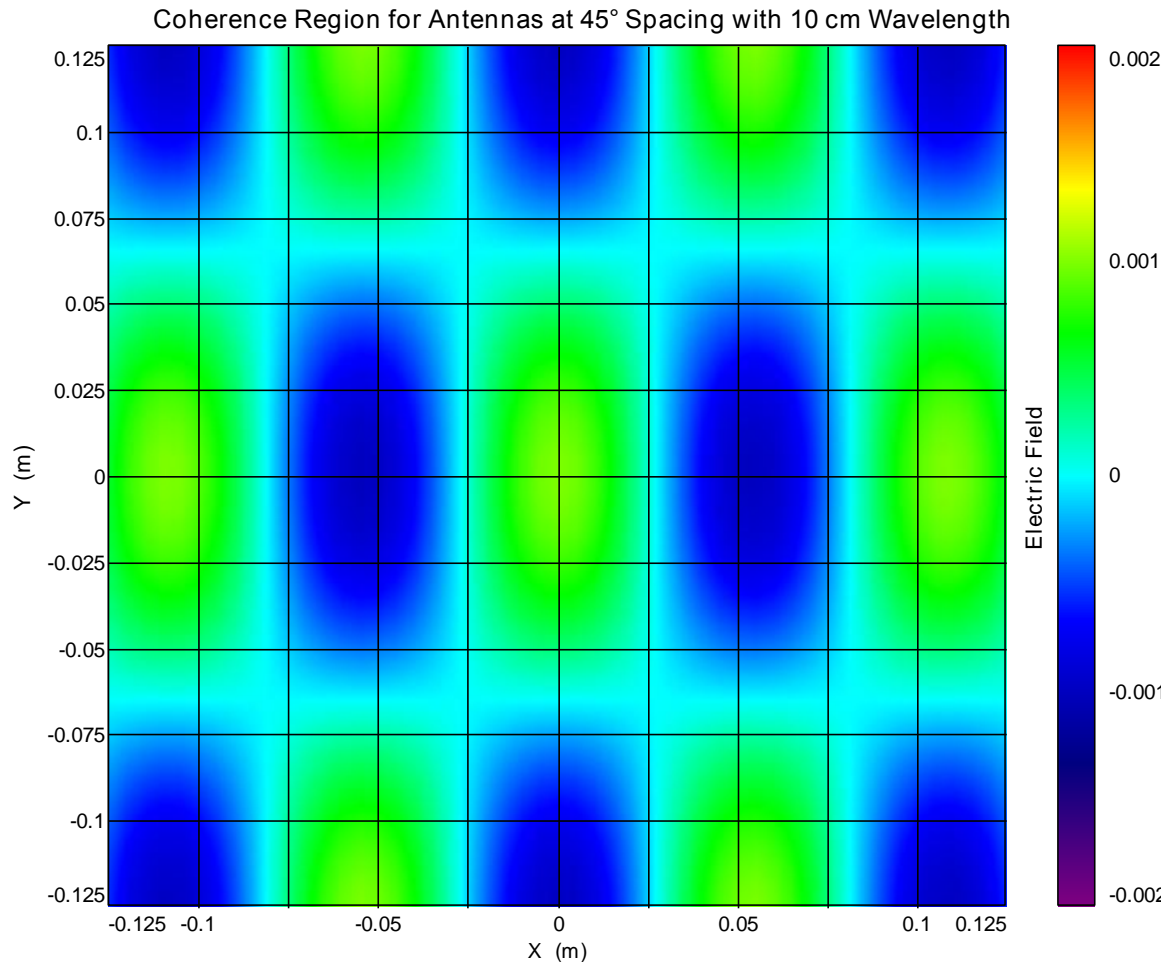

Spatial Environment Simulation

■ Effect of angular resolution on simulated AOA.

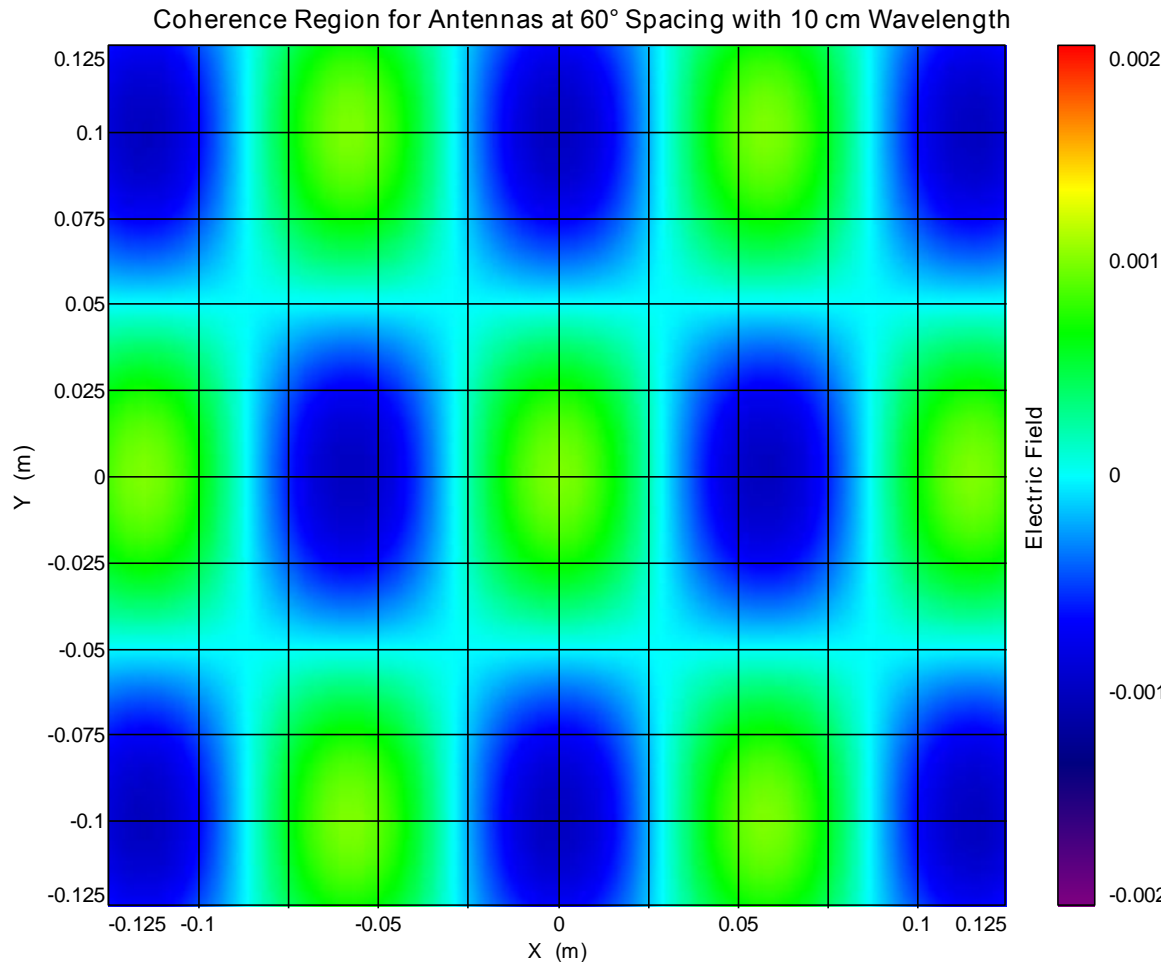

Spatial Environment Simulation

- A perfect spherical boundary condition produces perfect spherical symmetry.

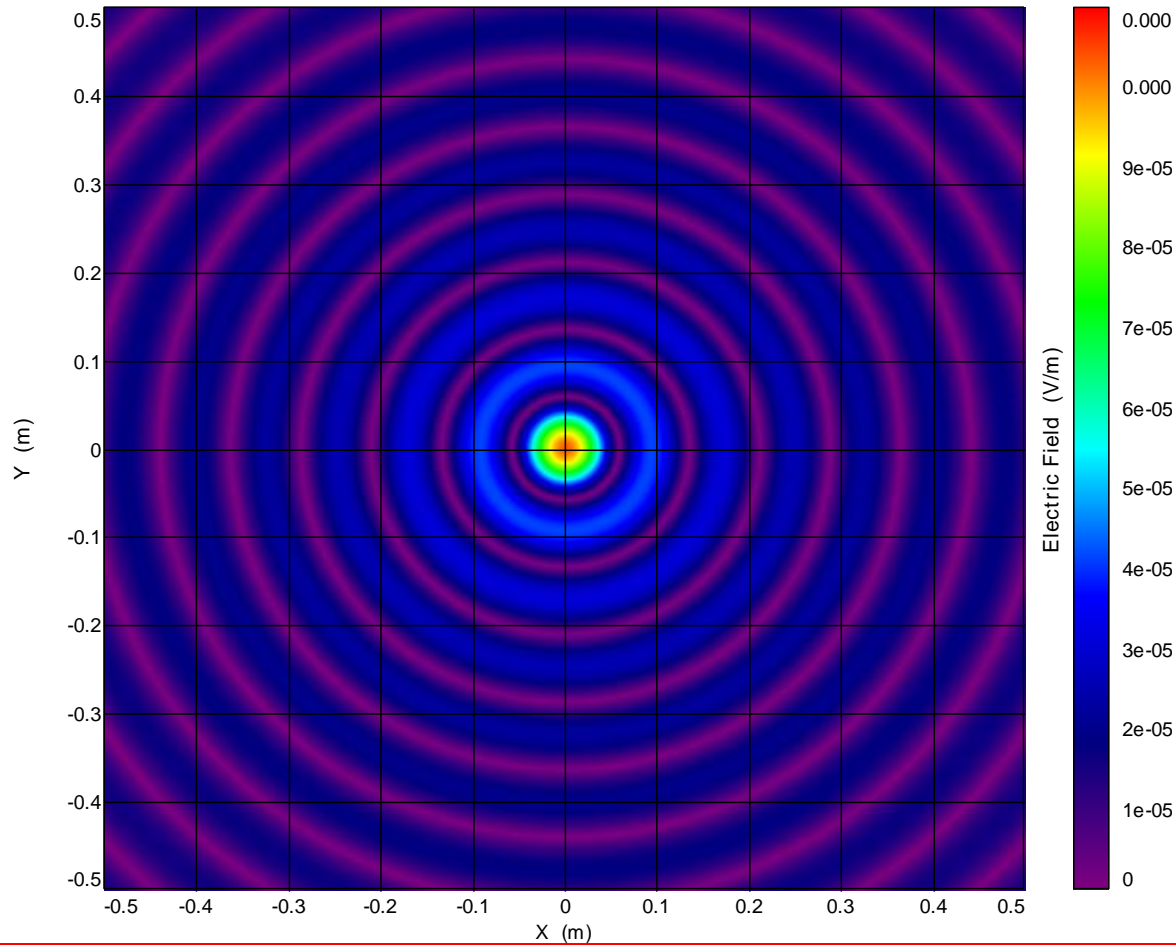

Spatial Environment Simulation

- Using only eight antennas at 45° spacing produces a uniform test volume that's only about a wavelength.

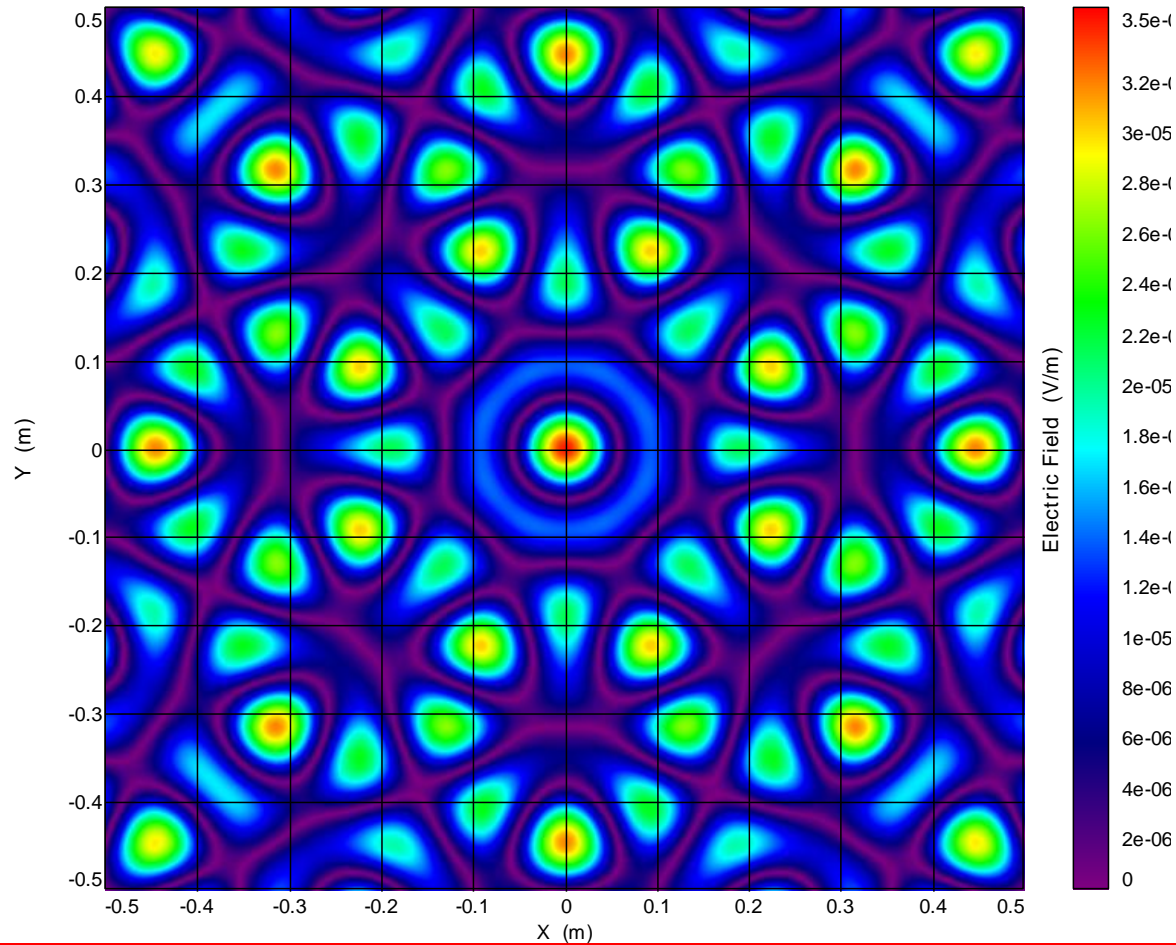

Spatial Environment Simulation

- Using 24 antennas at 15° spacing produces a much larger uniform test volume.

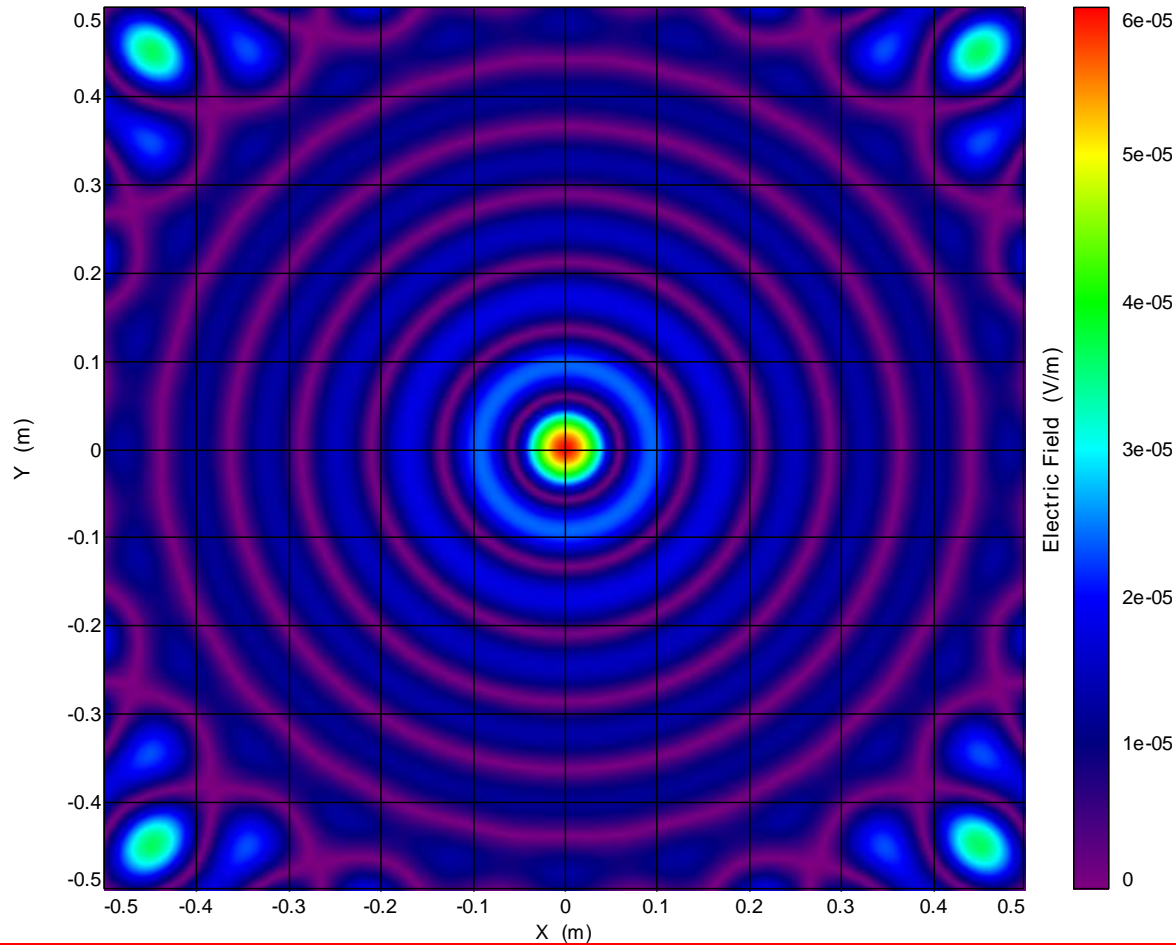

Spatial Environment Simulation

- Radial fall-off from traditional antennas in close proximity to DUT does not behave like reflections from distant objects (i.e. non-plane-wave behavior).

Relative Signal Strength for Point Source at 1.0 m Distance

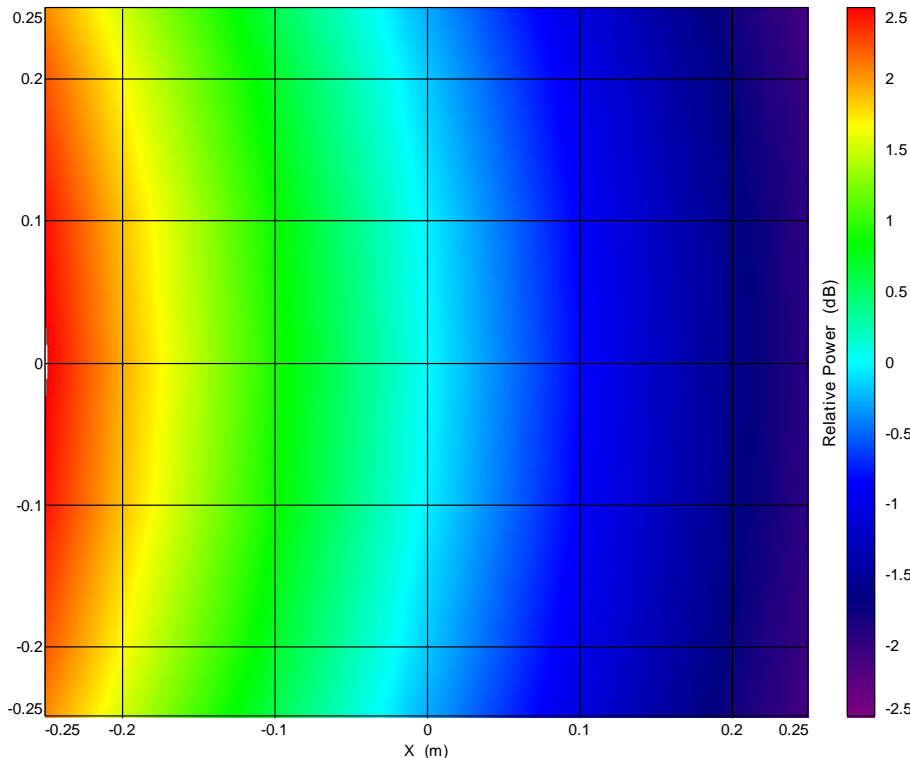

Relative Signal Strength for Point Source at 3.0 m Distance

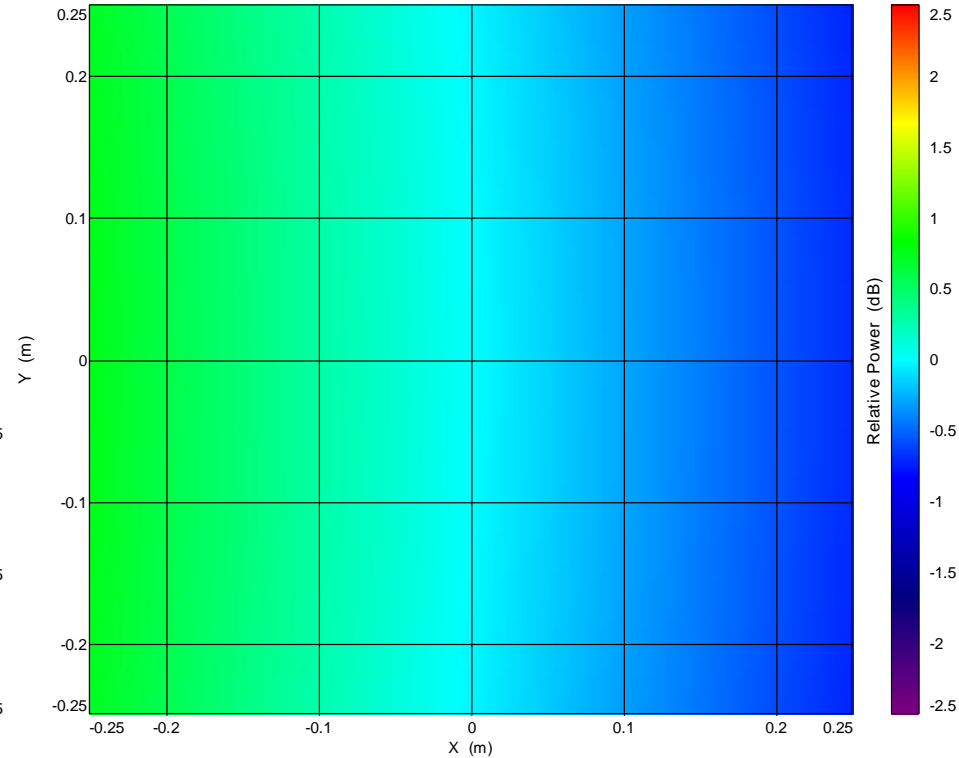

Standardization of MIMO OTA Testing

- **CTIA, 3GPP, COST all looking at MIMO OTA. WiMAX Forum is also interested.**
- **CTIA MIMO Anechoic Chamber subgroup (MACSG) has been merged with Reverb Chamber subgroup (RCSG) to create the new MIMO OTA subgroup (MOSG)**
- **This has slowed the pace of CTIA development similar to 3GPP as more approaches are proposed to MOSG.**

Standardization of MIMO OTA Testing

- **3GPP finished its second round robin to evaluate methodologies.**
- **Round robin originally planned to prove reproducibility of MIMO anechoic method.**
- **Was expanded to add comparison between all methodologies.**
- **Usefulness of the results is limited due to some limitations in the process.**

ETS-Lindgren Intellectual Property

- We published first papers on this topic in 2006, after applying for multiple patents.
- **20080056340 – “Systems and methods for over the air performance testing of wireless devices with multiple antennas”**
 - Anechoic array MIMO OTA concept using channel emulator, delay lines, etc.
- **20080305754 – “Systems and methods for over-the-air testing of wireless systems”**
 - Covers anechoic, reverb, lossy reverb, delay lines, etc. as well as combinations thereof.

ETS-Lindgren Intellectual Property

- **Patent #7,965,986 “Systems and methods for over-the-air testing of wireless systems” has been granted based on 20080305754.**

AMS-8700 Environment Simulator

- The MIMO OTA Environment Simulation System is referred to as the AMS-8700 series.
- The baseline AMS-8700 has eight dual polarized antennas and one 8-ch channel emulator.
- The mounting ring allows different spacing to support single cluster & distributed configurations.

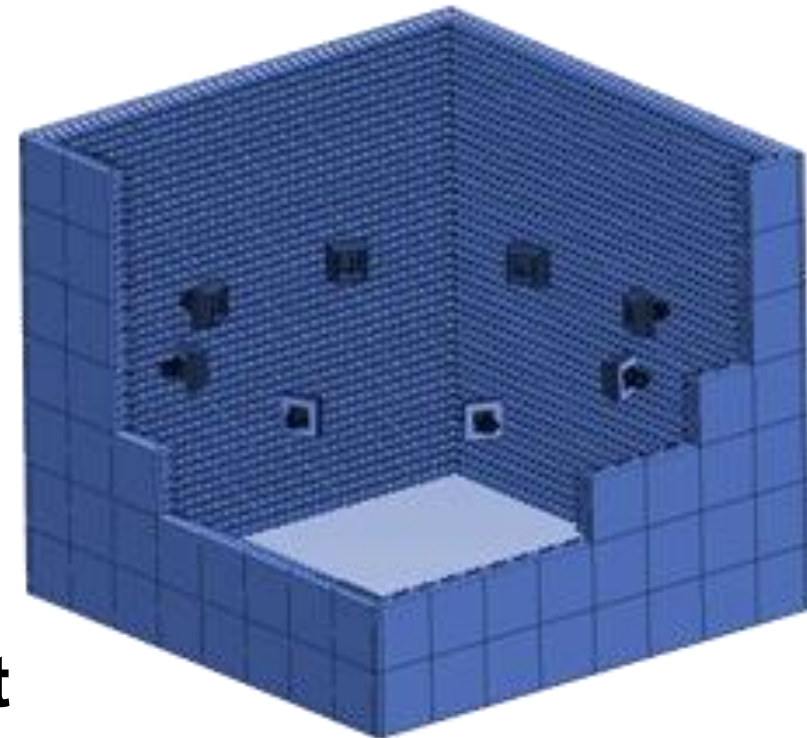

AMS-8700 Environment Simulator

- The baseline provides only eight active elements, switchable between vertical & horiz.

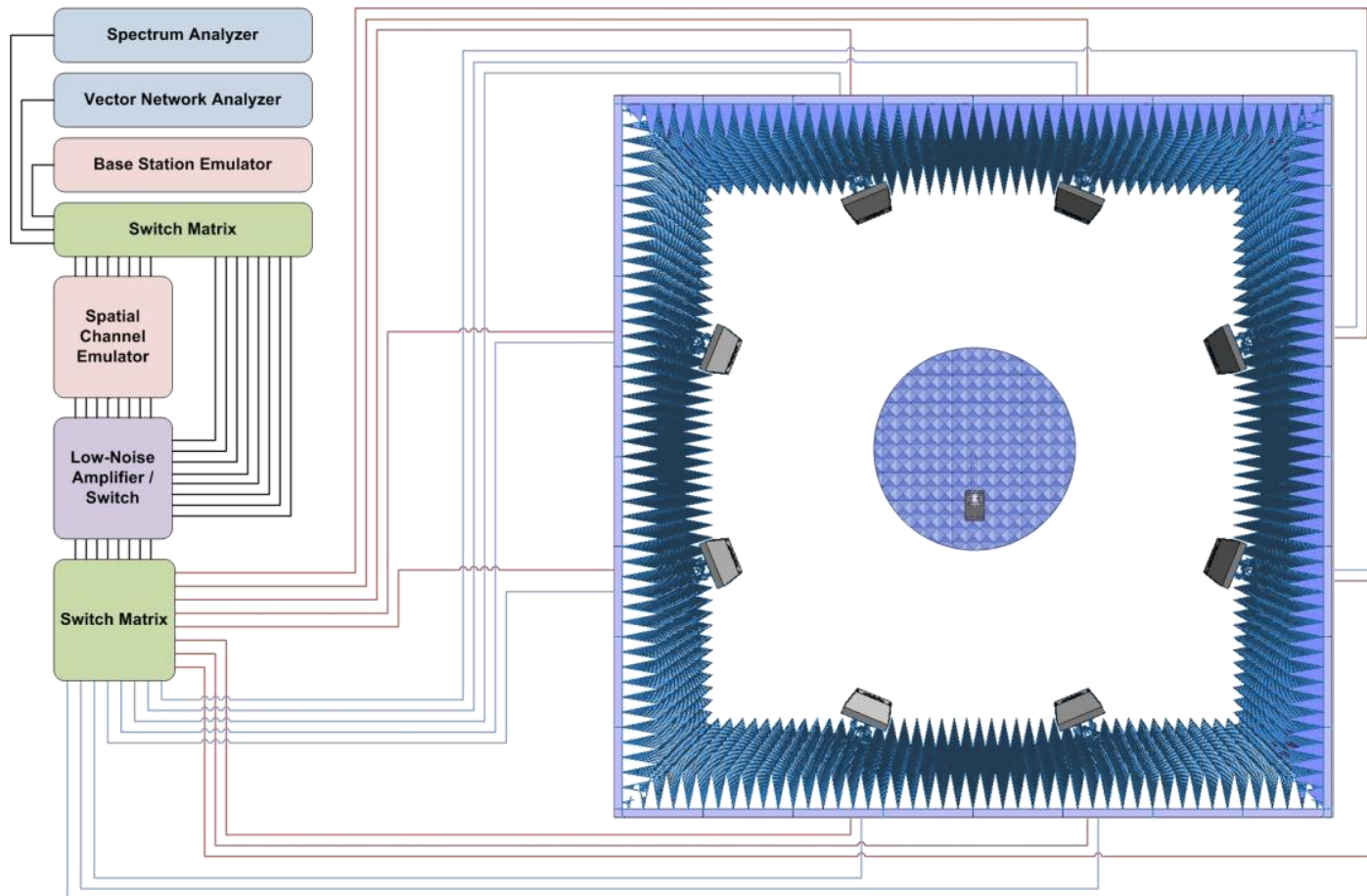

AMS-8700 Environment Simulator

- A base station with throughput testing options is used for MIMO.
- A VNA with multiple channels can be used for evaluating correlation of embedded MIMO antennas.
- A MAPS is provided for 3-D tests.
- An additional SISO-only antenna can be added for TRP/TIS.
- Other antenna configuration/test options are available.

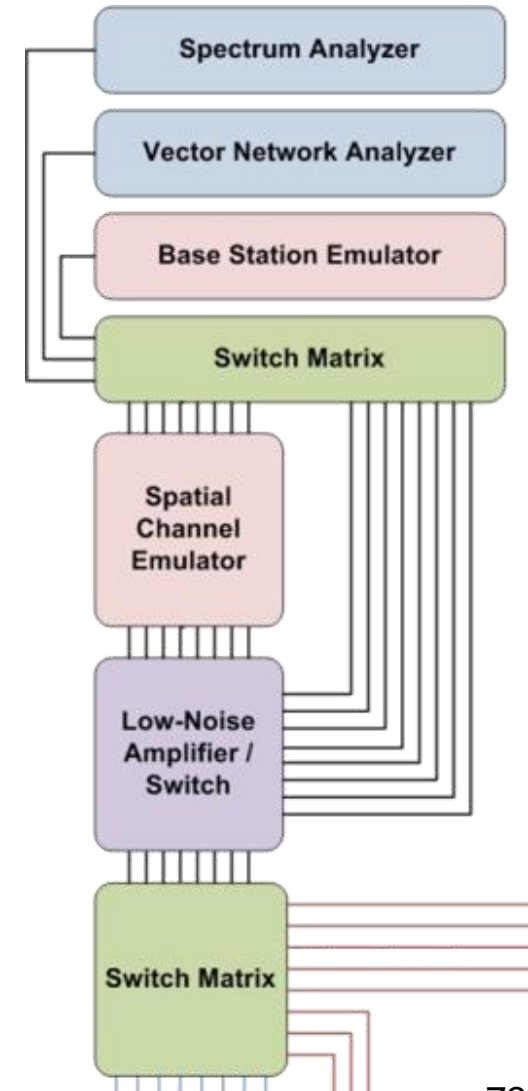

AMS-8700 Environment Simulator

- EB's was the first to market with an OTA channel emulator solution.
- They include an OTA modeling tool for creating OTA spatial channel models.

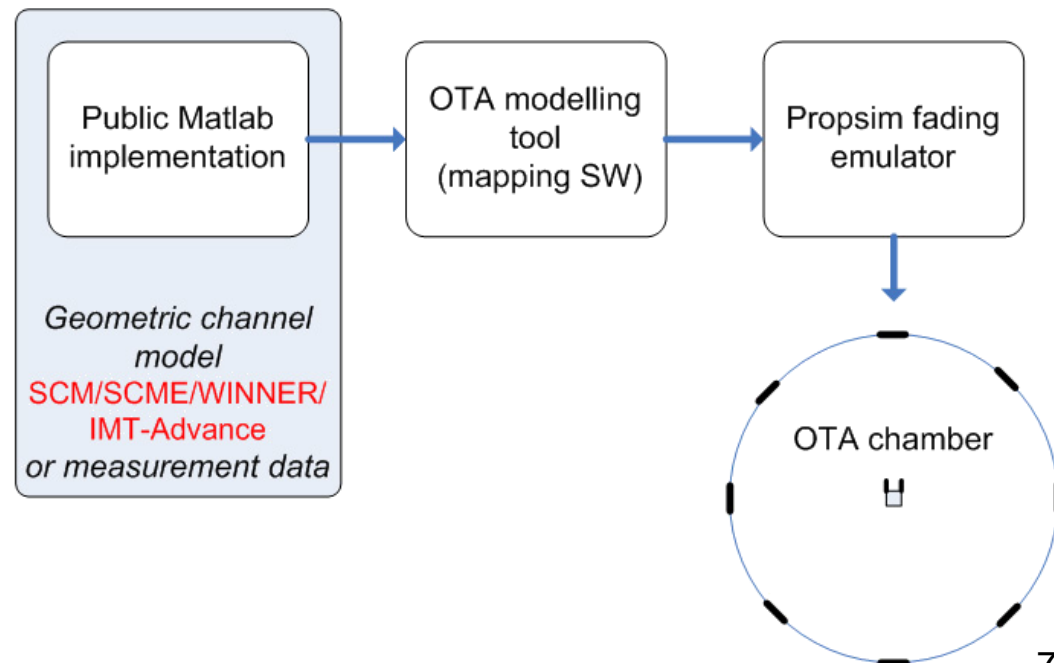

AMS-8700 Environment Simulator

- Additional antennas can be added (up to the available space on the ring) by adding the required number of channel emulators.
- Minor incremental cost to the chamber but multiplies the instrumentation cost.

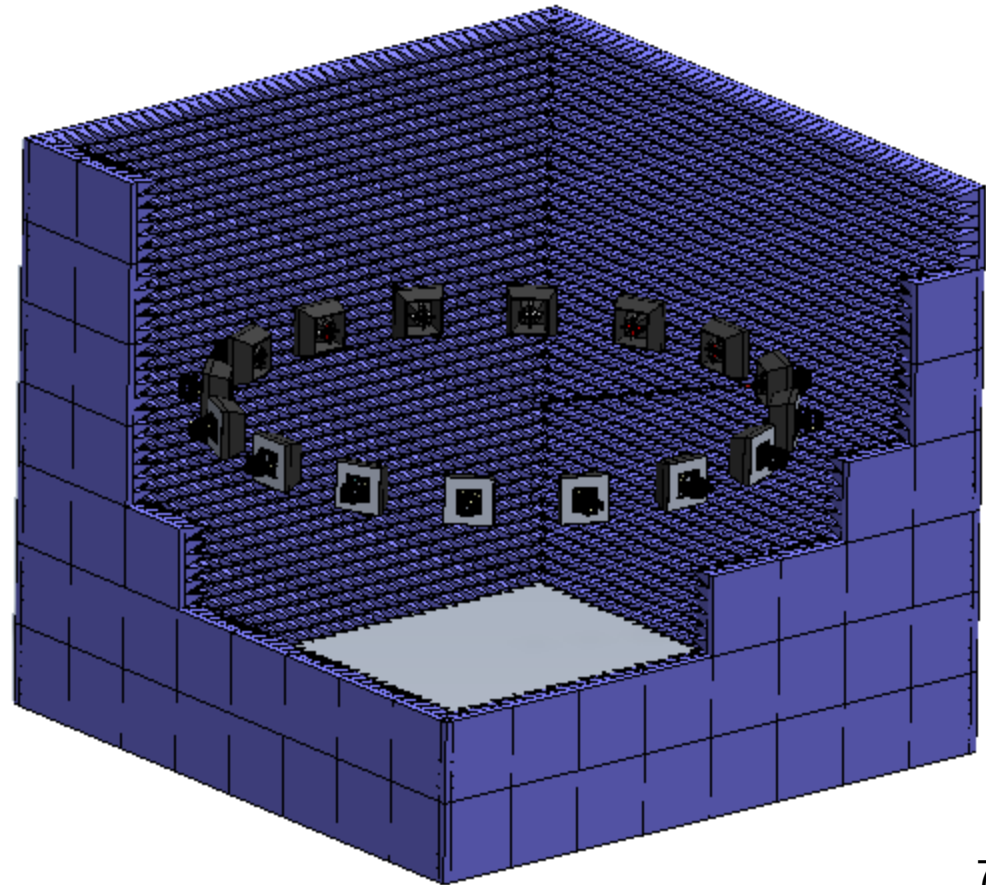

AMS-8700 Environment Simulator

- An AMS-8900 can be combined with an AMS-8700 to allow high speed APM and TRP/TIS.
- Chamber cost is a fraction of overall system cost.
- User must weigh value of doing APM/TRP/TIS vs. having inactive channel emulator(s).

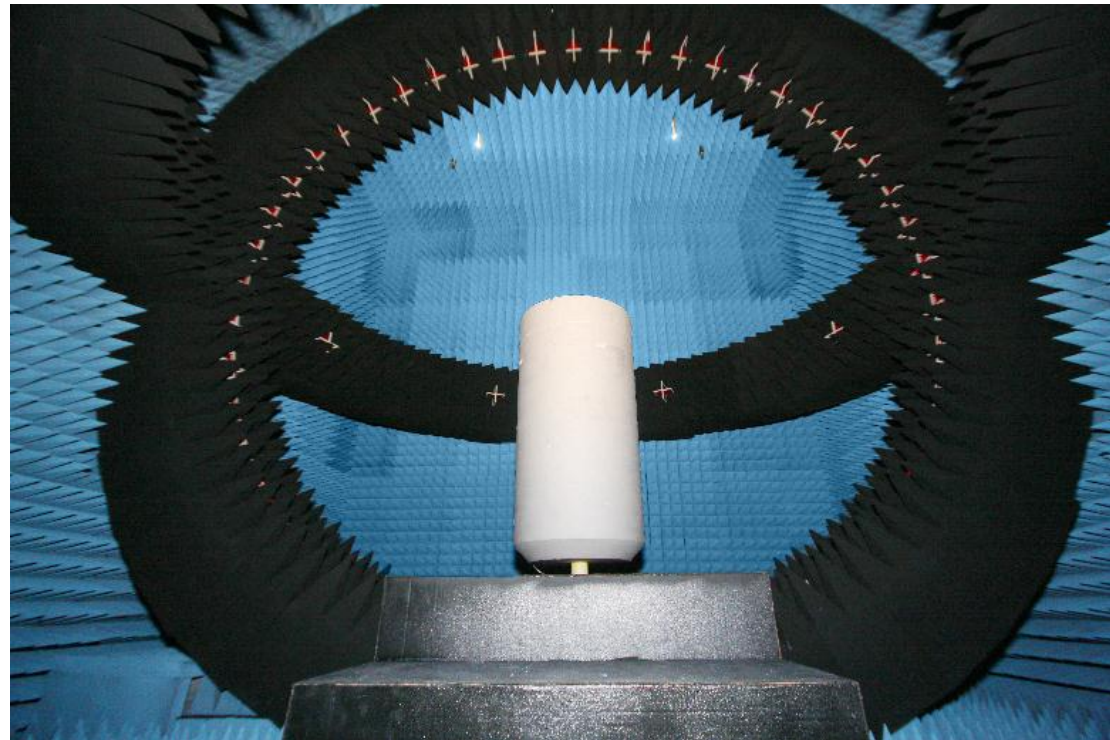

EMQuest EMQ-108 MIMO OTA Testing

- An optional EMQ-108 MIMO OTA expansion module has been added to EMQuest.
- Option adds support for channel emulators as variable gain devices.
- Includes calibration/validation tests for spatial channel emulation.
- Includes special vector APM post processing for calculating antenna envelope correlation.
 - Will be sold as a separate option as well.

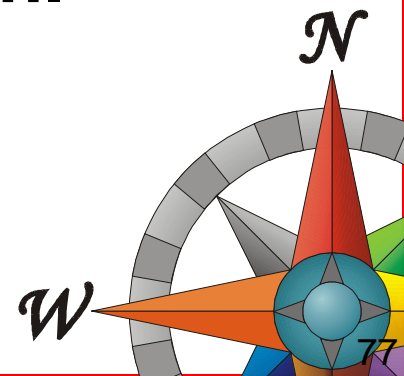

EMQuest EMQ-108 MIMO OTA Testing

- **Requirements of MIMO OTA introduce a higher level of complexity to system and test automation.**
 - Interactions between BSE/VSA, channel emulator, and amplifiers.
 - Uplink port isolation.
 - Validation tests produce huge data sets.
- **An adequate level of software control is required to automate the calibration and test routines.**

Calibrating the System

- A typical RF channel emulator consists of a number of VSA receivers and VSG transmitters connected to a DSP modeling core that introduces delay spreads, fading, etc. at baseband.

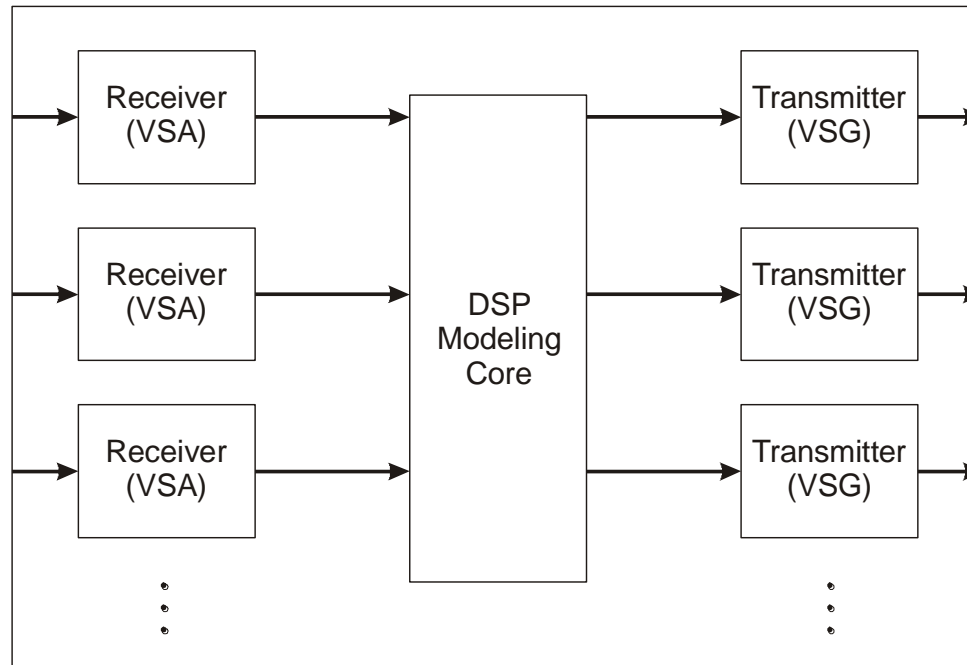

Calibrating the System

- The ideal channel emulator routes multiple inputs to multiple outputs after applying appropriate modeled delay spreads, fading, etc.

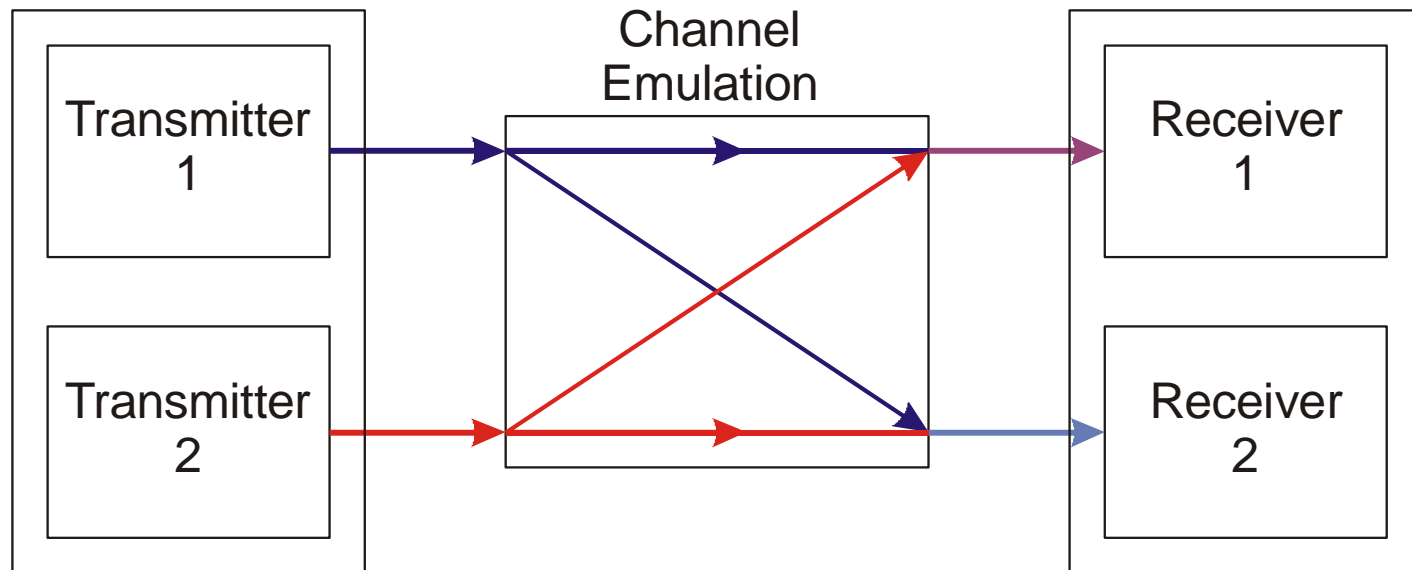

Calibrating the System

- In a real system, there are external path losses that must be accounted for.
- For an OTA system, this includes cable losses, antenna gains, and range path losses.
 - External amplifiers are also typically required

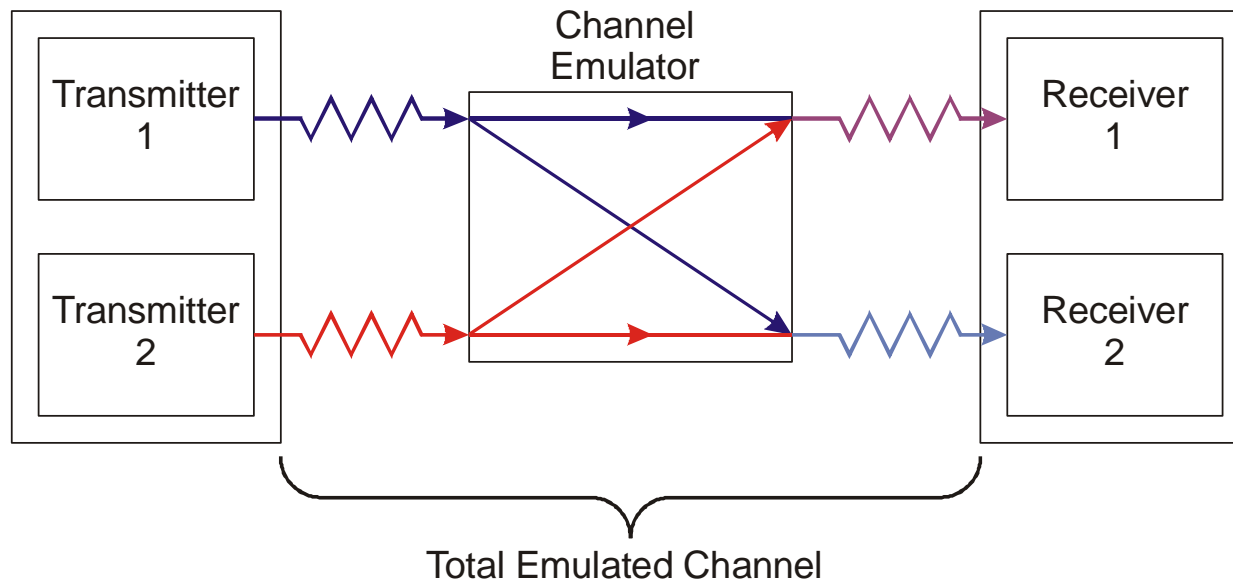

Calibrating the System

- For input calibration, the requirement is that

$$G_{11} + G_{12} = G_{21} + G_{22} = G_{X1} + G_{X2}$$

so that $P_A = P_B = P_X$, when P_{TX} is applied to each input cable.

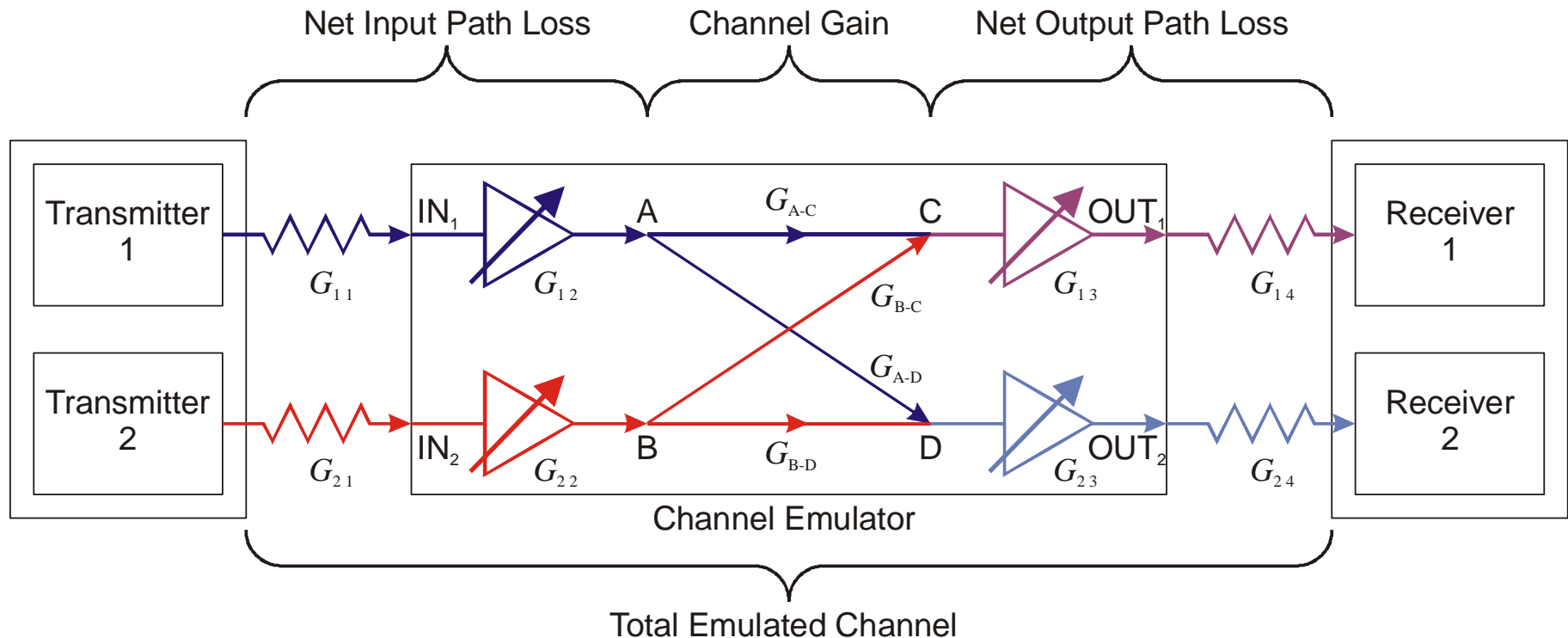

Calibrating the System

- Similarly, for output calibration, requirement is that

$$G_{13} + G_{14} = G_{23} + G_{24} = G_{X3} + G_{X4}$$

so that net losses to test volume are equal.

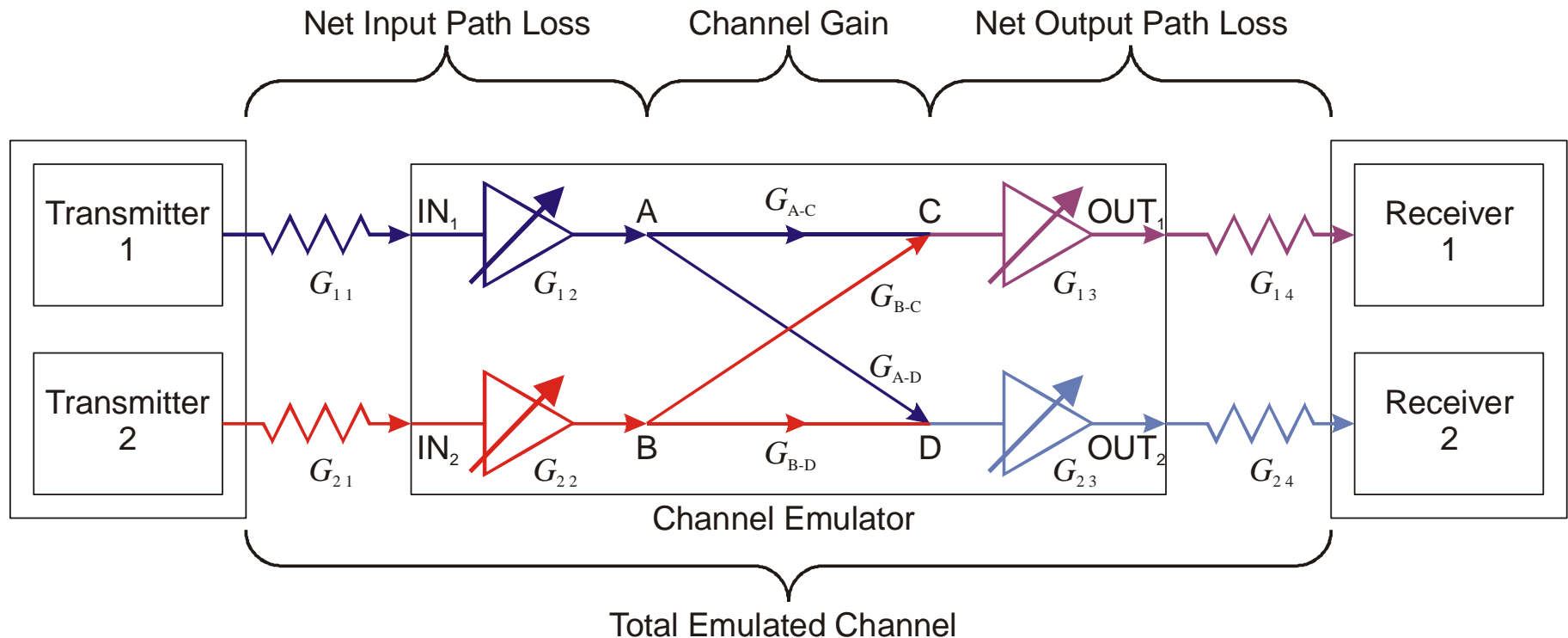

Calibrating the System

- Simple channel model with four equivalent inputs (red) and eight resulting outputs (blue).

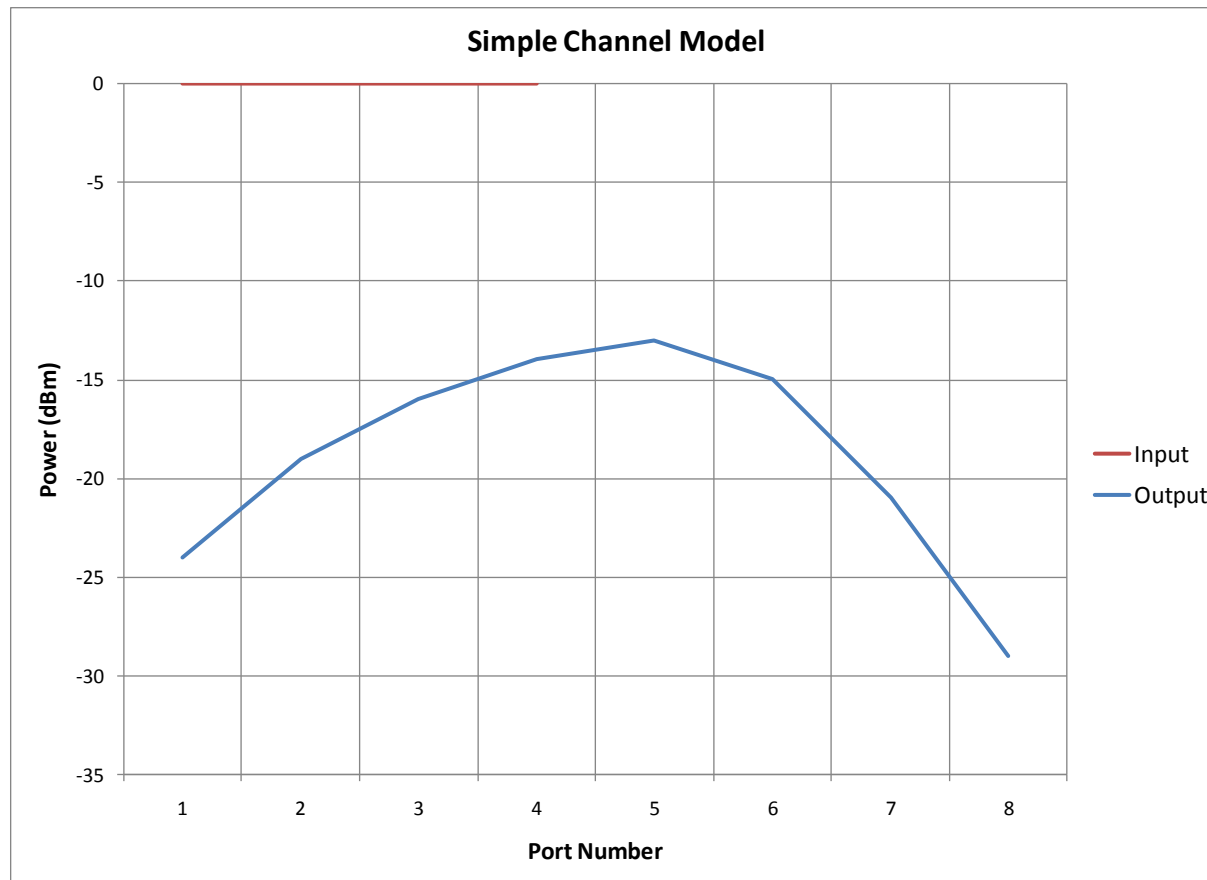

Calibrating the System

- Result of input and output path losses applied to channel model.

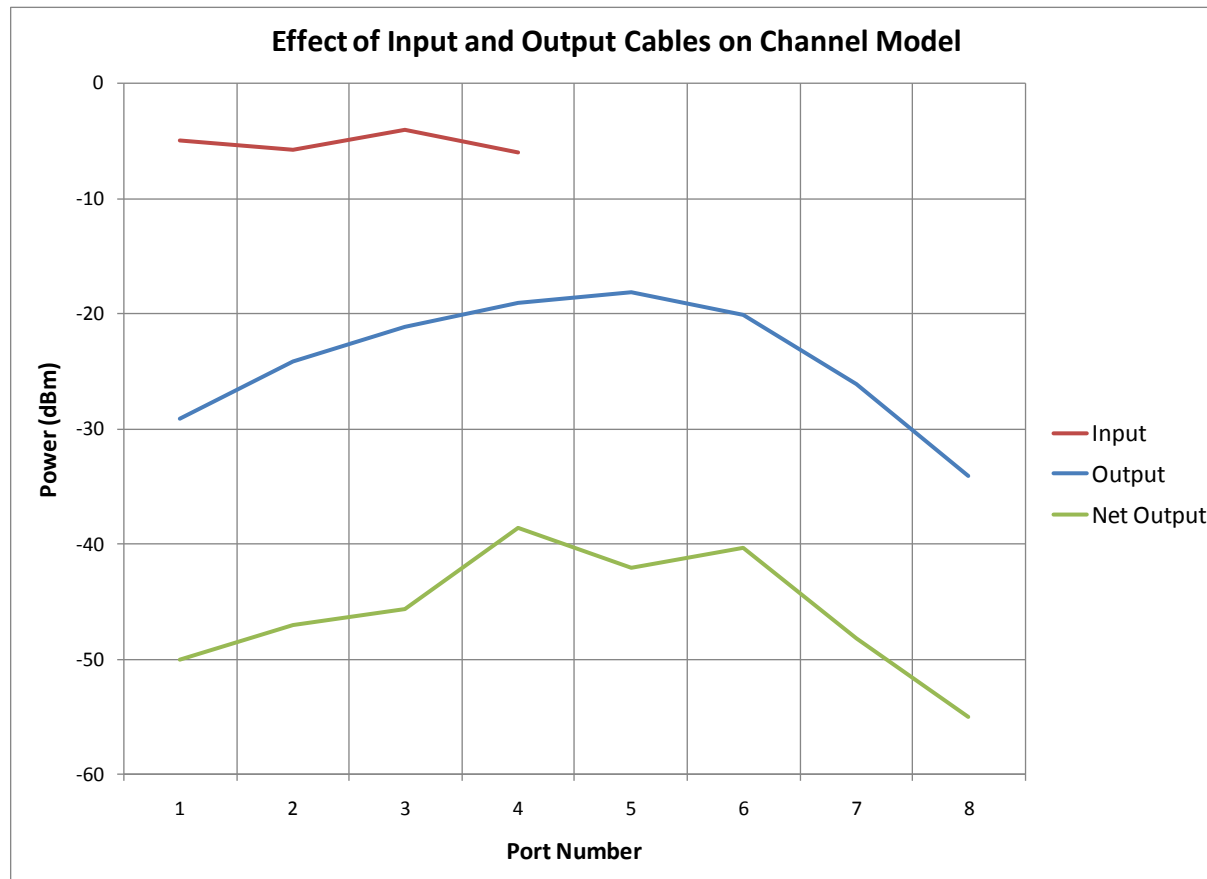

Calibrating the System

- Correcting for relative input losses (purple) flattens inputs to channel model. Net output is still wrong.

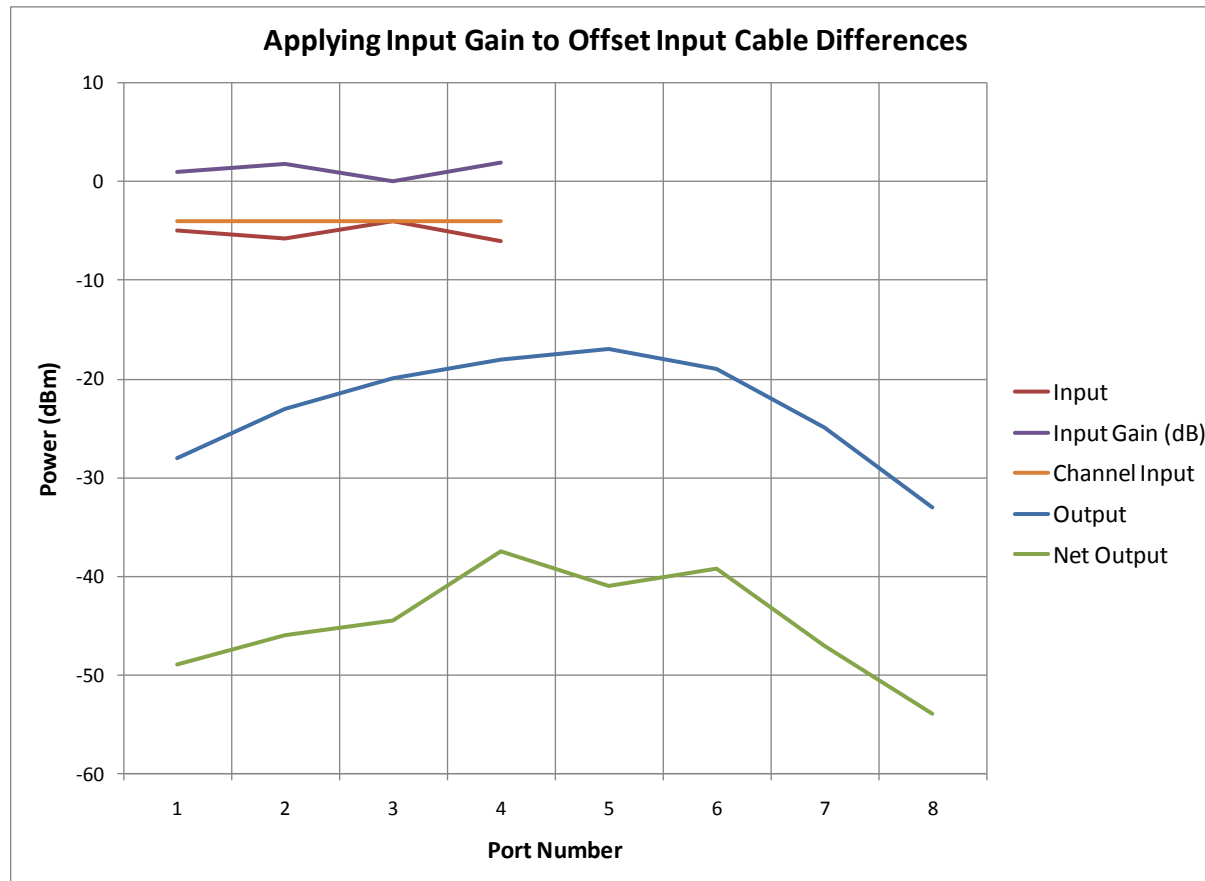

Calibrating the System

- Correcting the relative output levels reproduces the desired impact of clusters within the environment.

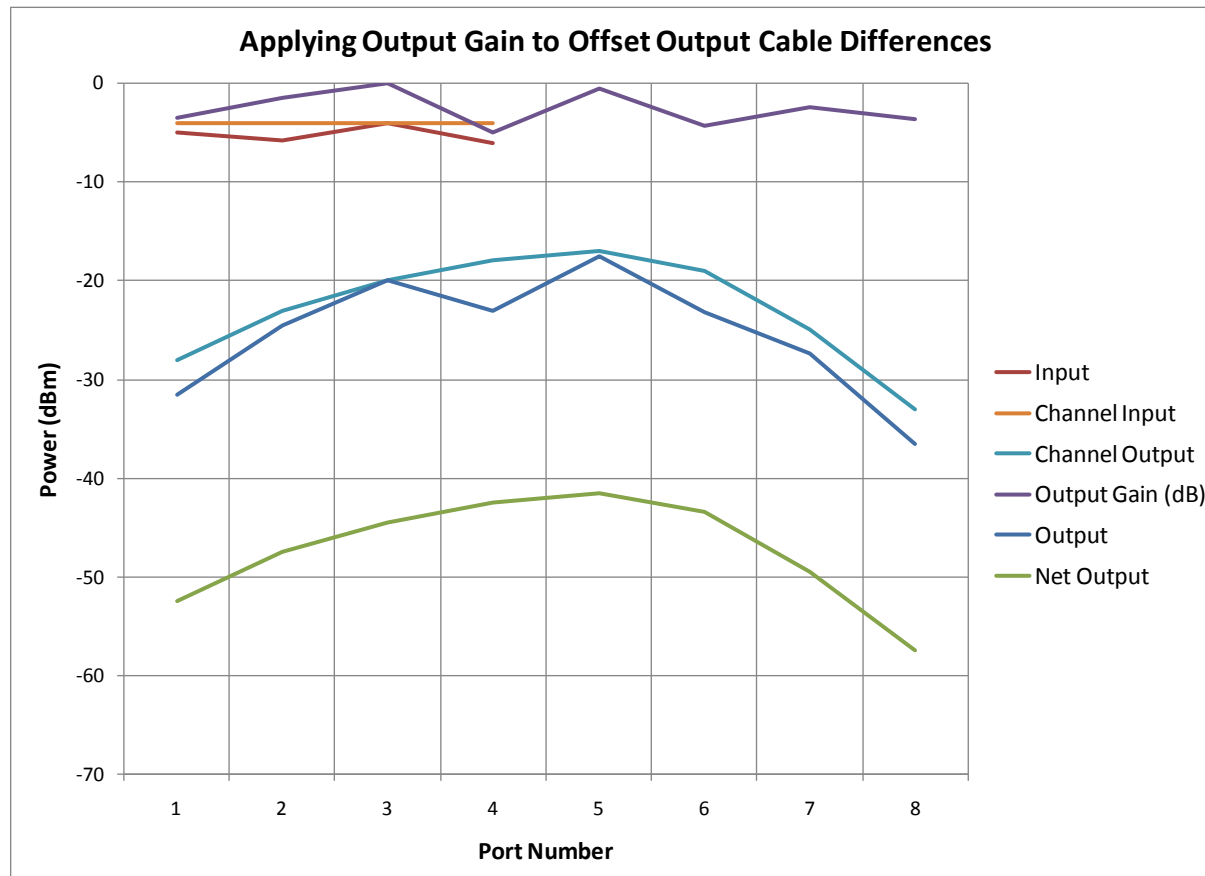

Calibrating the System

- **Finally, to predict the average power level in the center of the test volume, the average path loss must be calculated, including the loss (gain) of the channel model.**
- **This requires detailed knowledge of the channel model gains, as well as assumptions about the relative input levels of each input path for MIMO.**
- **Application of a SIMO output calibration to a MIMO model requires understanding/adjustment of source power definition.**

Calibrating the System

$$g_i = G_{i1} + G_{i2} + 10 \log \left(\sum_{j=1}^N 10^{G_{Channel\ j} + G_{j3} + G_{j4}} \right)$$

where $G_{Channel}$ is the gain of a single channel path.

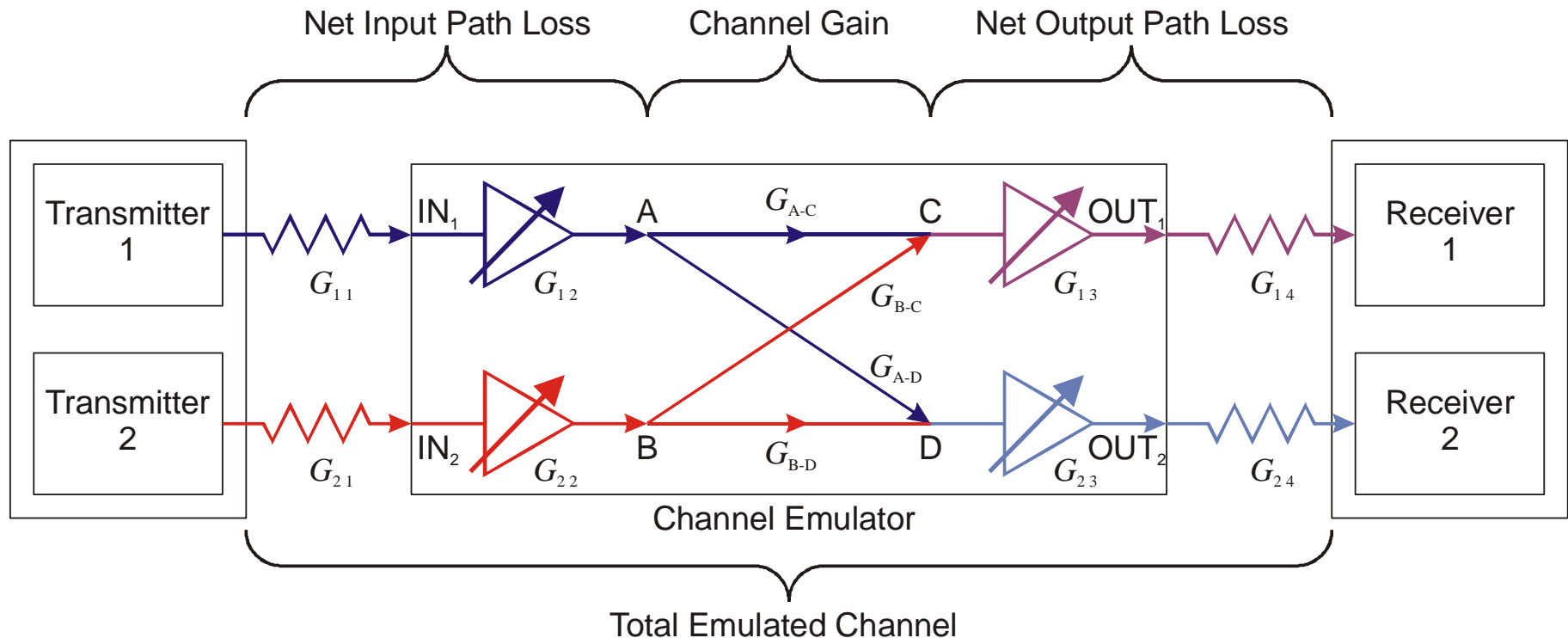

Calibrating the System

- However, when properly calibrated

$$g_{output} = G_{j3} + G_{j4} = G_{13} + G_{14}$$

and likewise

$$g_{input} = G_{i1} + G_{i2}$$

so that

$$g_i = g_{input} + 10 \log \left(\sum_{j=1}^N 10^{G_{Channel\ j} + g_{output}} \right)$$

which can be simplified to:

$$g_i = g_{input} + g_{output} + 10 \log \left(\sum_{j=1}^N 10^{G_{Channel\ j}} \right)$$

Calibrating the System

- **This simplification shows that both the input and output gain of the system can be easily altered to address output levels and modulation headroom of the source, and to vary total path loss in the system.**
 - Such changes must be accounted for in determining the power in the test volume.
- **When changing channel models, the total channel model gain must be recalculated.**
- **Changing the number of active inputs and outputs also alters the gain.**

Calibrating the System

- When evaluating the gain of a MIMO system where the same power, P_{TX} , is applied to each input cable, the total gain to the test volume can be given by:

$$g_{total} = 10 \log \left(\sum_{i=1}^M 10^{g_i} \right)$$

- Note that this sum includes the array gain of the multiple transmitters. For average power gain,

$$g_{average} = 10 \log \left(\frac{1}{M} \sum_{i=1}^M 10^{g_i} \right)$$

System Validation

- **A wide range of tests are possible to evaluate:**
 - Chamber/RF system quality
 - Channel emulation quality
 - Calibration quality
 - Combined system performance
- **Many tests are more interesting for research purposes rather than system validation**
- **It's important to separate out tests that provide useful system information vs. component level performance.**
 - E.g. correlation or field distribution vs. Doppler spread

System Validation

- A re-configurable ETS-Lindgren AMS-8700 MIMO OTA system with 16 dual polarized antennas and two 8-output channel emulators was evaluated.

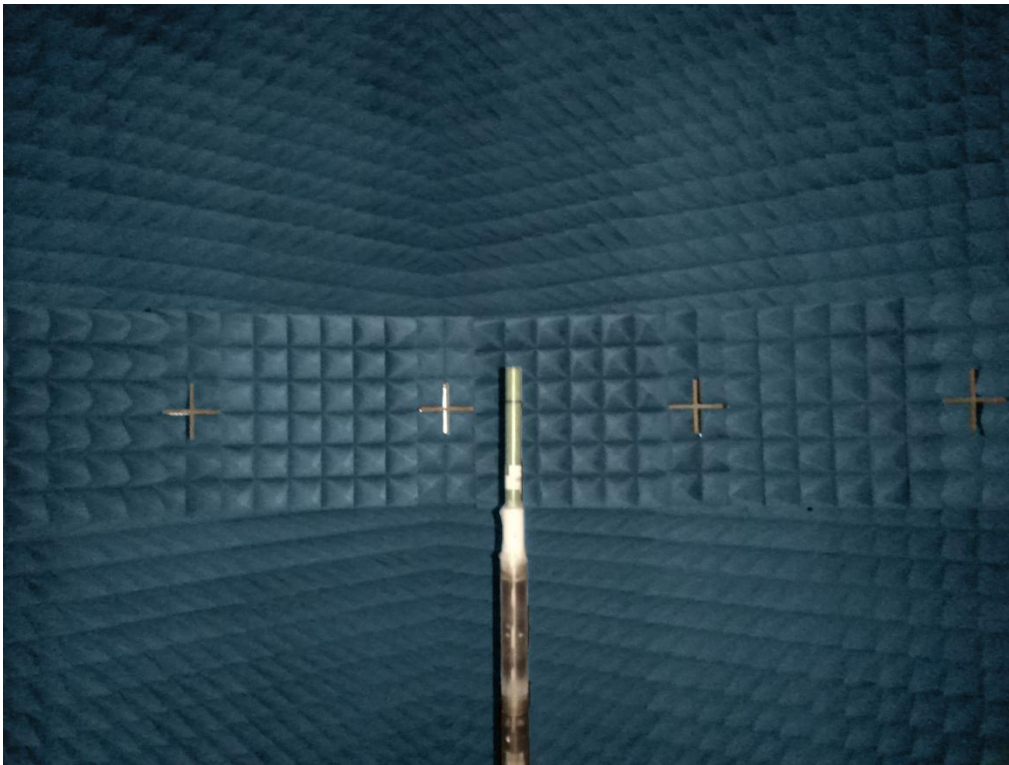

System Validation

- A linear positioner and turntable were used to map a 1 m diameter disc in the center of the test volume at 1 cm by 1 degree (0.87 cm at edge) resolution.

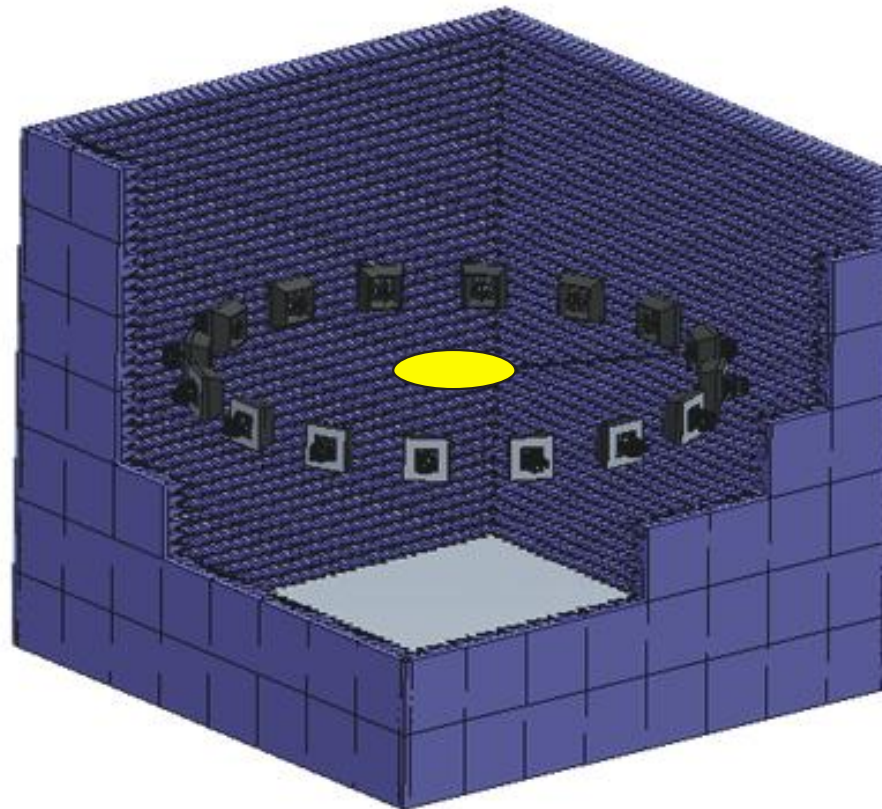

System Validation

- **Spatial Field Mapping is used to compare the measured environment to a theoretical model.**

Ideal Free-Space or Continuous Boundary Condition

Calculated Far-Field Field Structure with High Resolution Boundary Condition

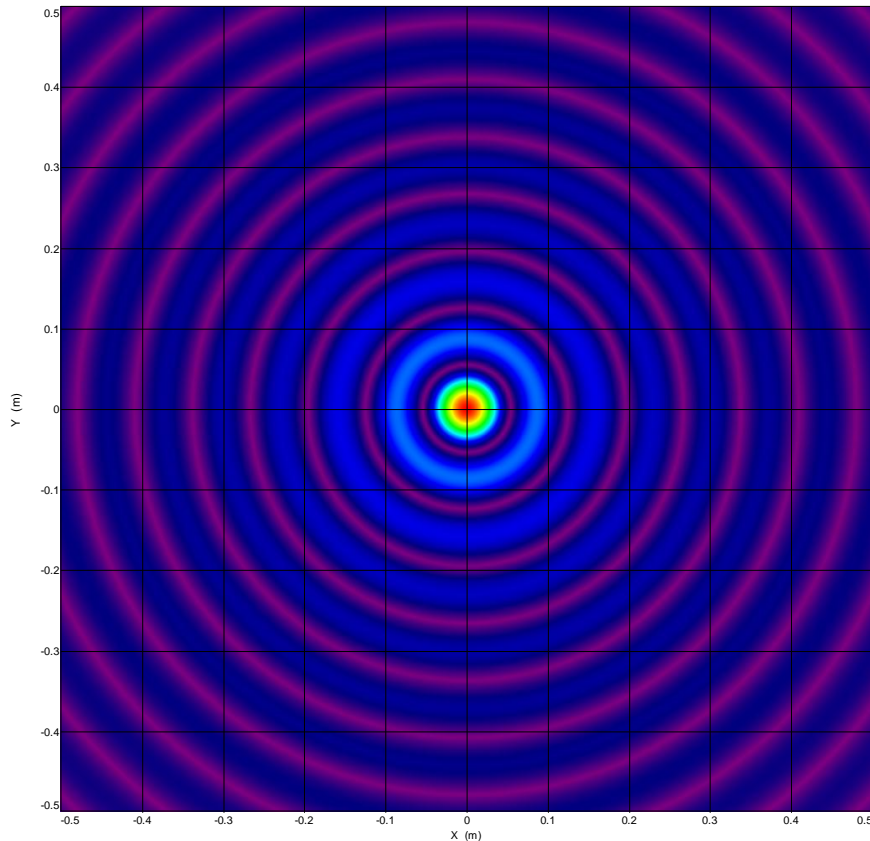

Interference Pattern from Eight Evenly Spaced Plane Waves

Calculated Far-field Field Structure, 45 Degree Spacing

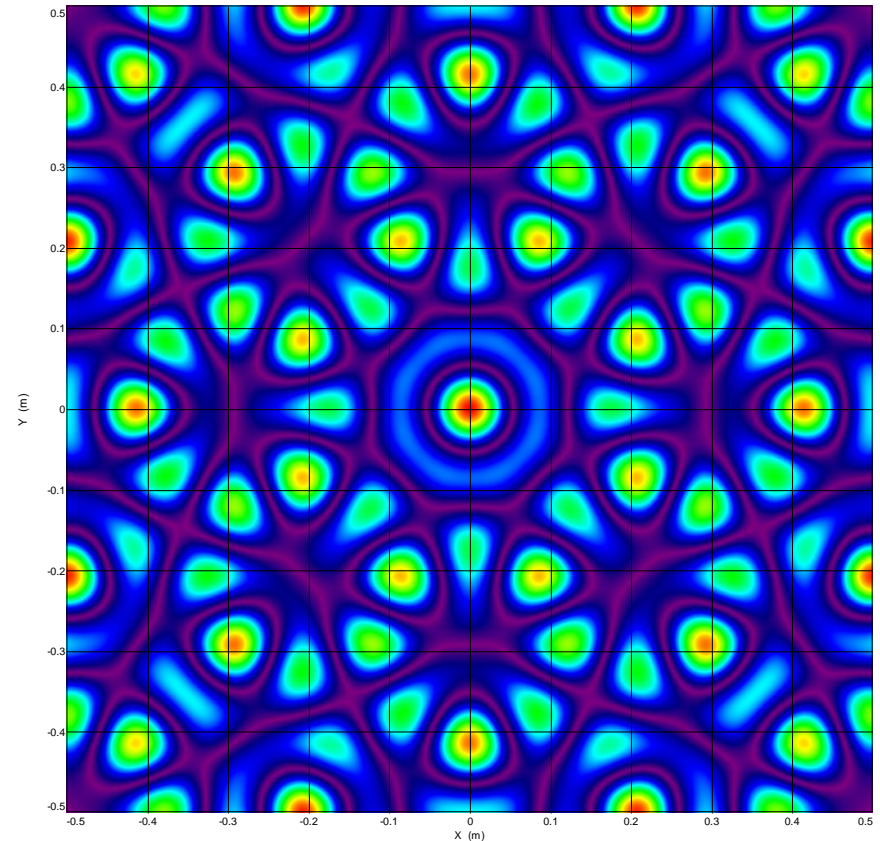

System Validation

■ **Modeling a 2 m range length instead of a plane wave shows excellent correlation.**

Measured Interference Pattern from Eight Antennas, $r = 2$ m

Measured Field Structure, 45 Degree Spacing, Vertically Polarized

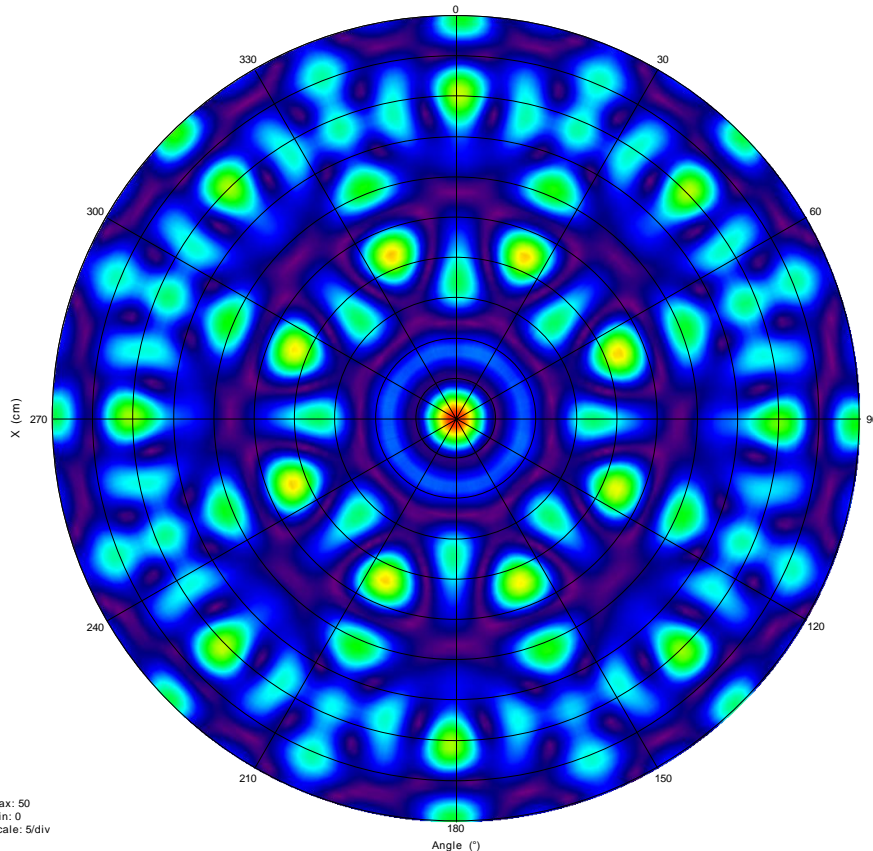

Max: 50
Min: 0
Scale: 5/div

Calculated Interference Pattern from Eight Antennas, $r = 2$ m

Calculated Field Structure at 2.0 m Radius, 45 Degree Spacing

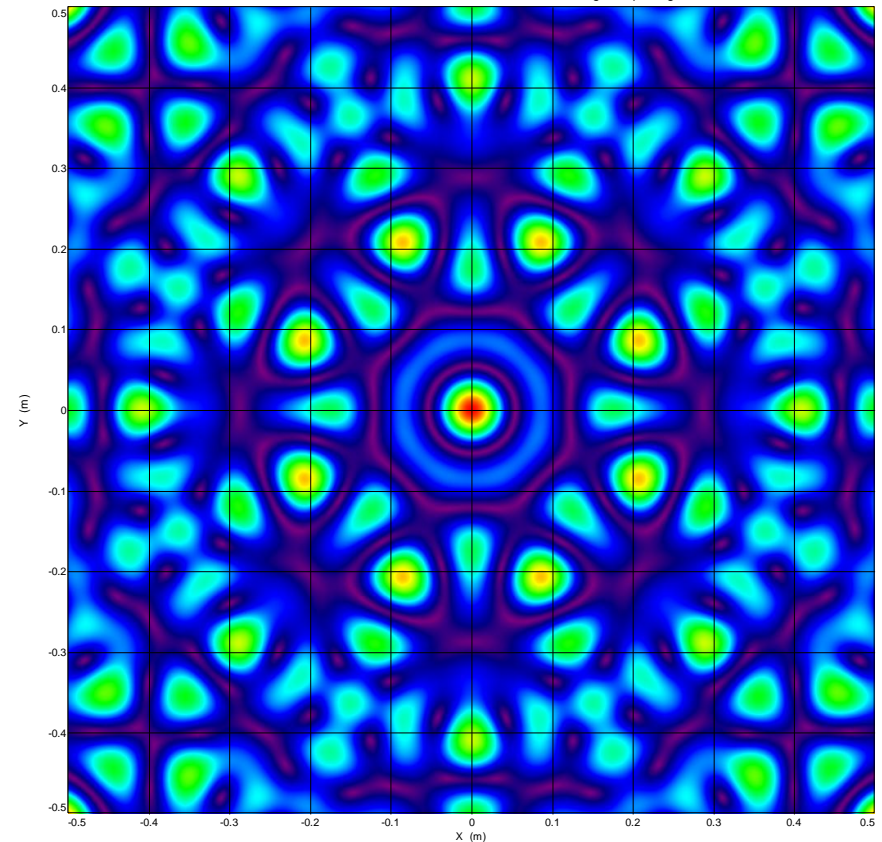

System Validation

■ Comparing a single cut through the test volume.

Comparison of Measured Field Structure to Theory for 8 Antenna Array (45° Spacing)

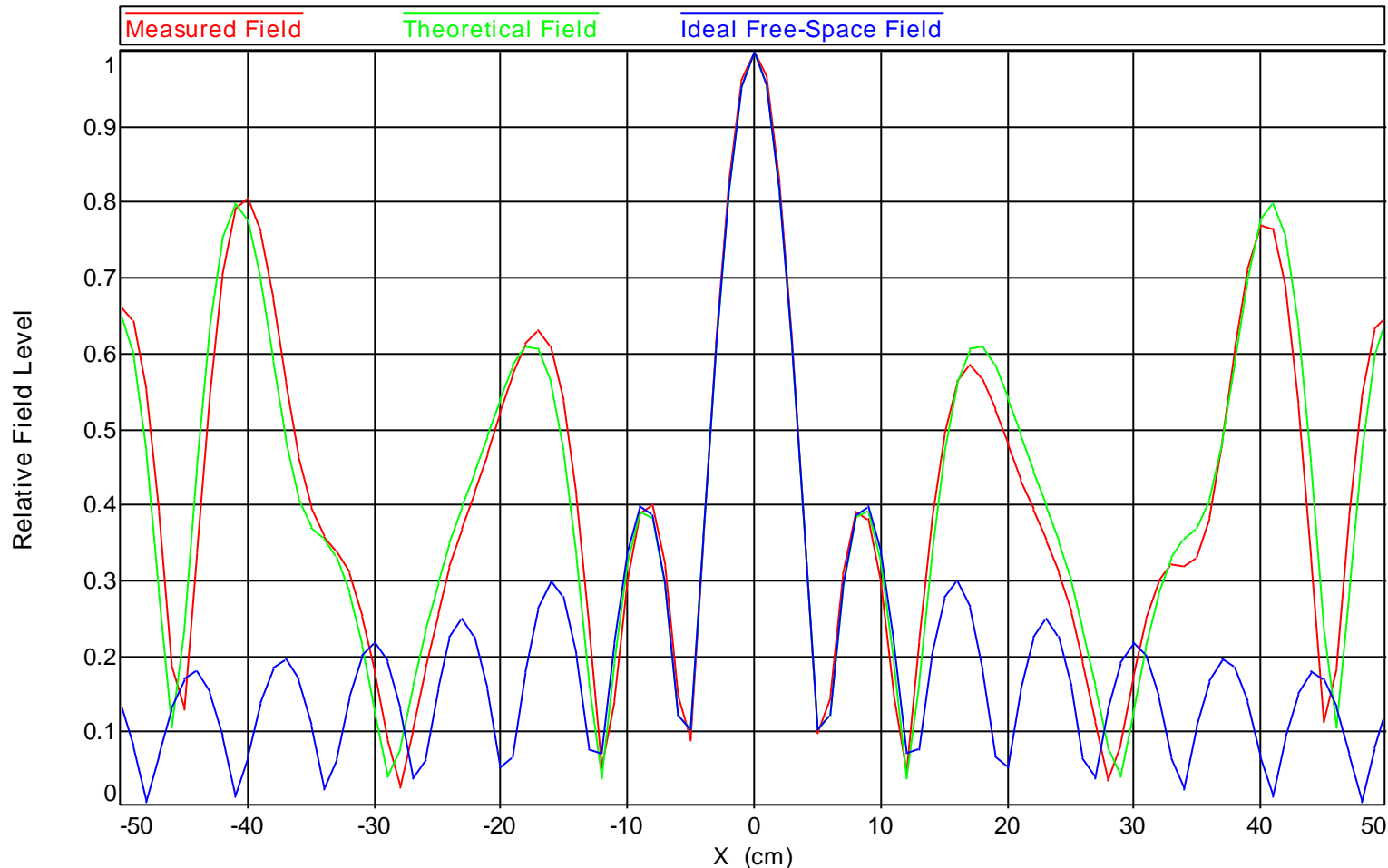

System Validation

- Increasing the resolution of the boundary condition from 8 to 16 antennas increases usable test volume.

Measured Interference Pattern from 16 Antennas, $r = 2$ m

Measured Field Structure, 22.5 Degree Spacing

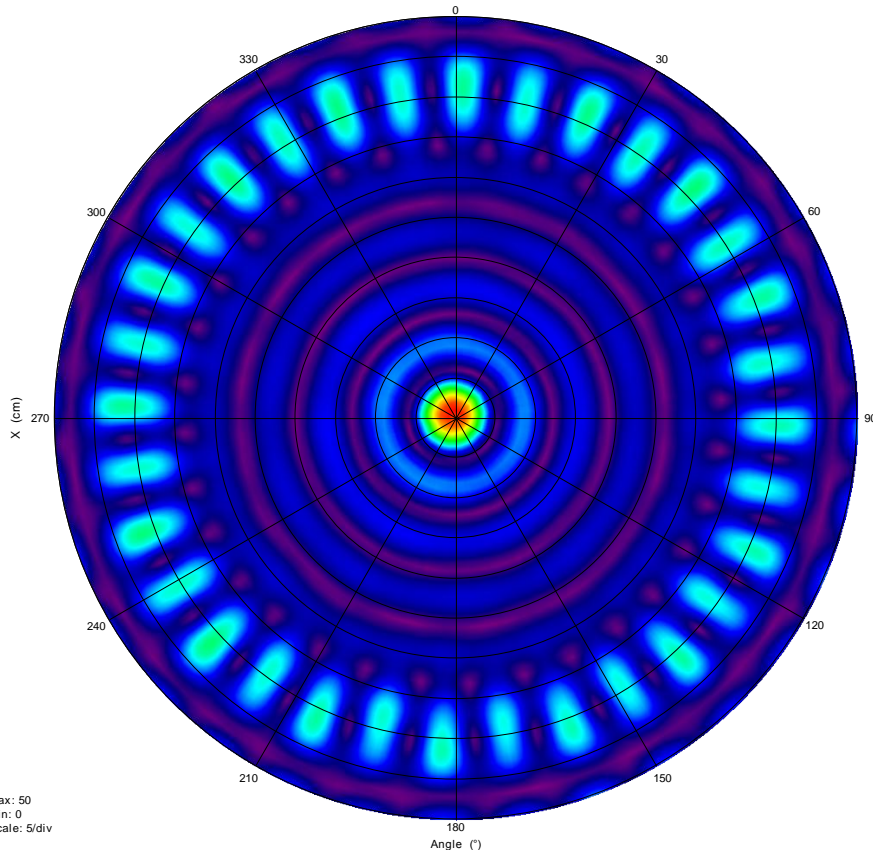

Calculated Interference Pattern from 16 Antennas, $r = 2$ m

Calculated Field Structure at 2.0 m Radius, 22.5 Degree Spacing

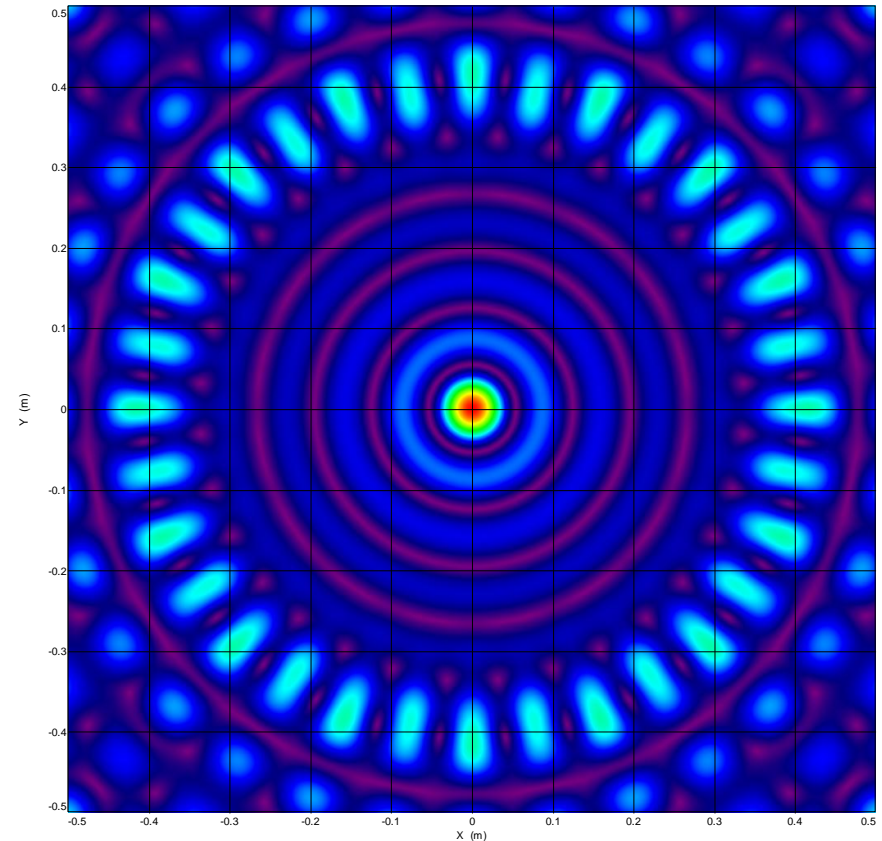

System Validation

- **Spatial Correlation evaluates field structure and channel model behavior.**
 - Move one dipole through test volume and evaluate correlation vs. separation.
 - Requires replay of channel model at each position.
 - Single cluster behavior most straightforward to evaluate.

1 m slice
through test
volume on
1 cm steps

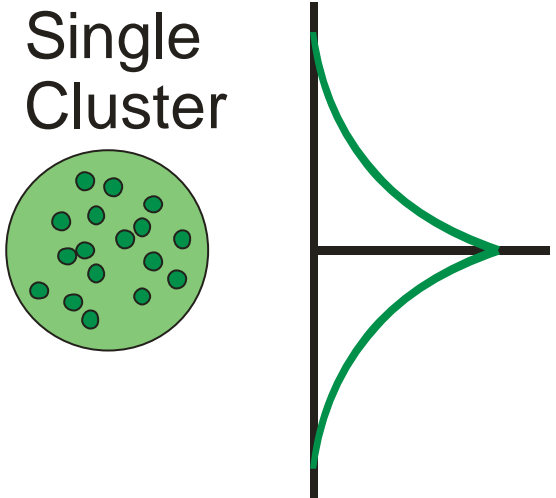
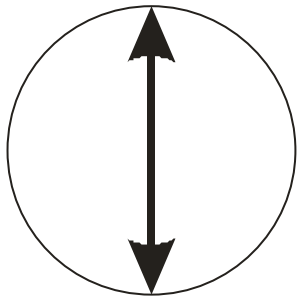

System Validation

- **Spatial Correlation evaluates RF system + emulation.**

Spatial Correlation for 8 Antenna (45° Spacing) Configuration

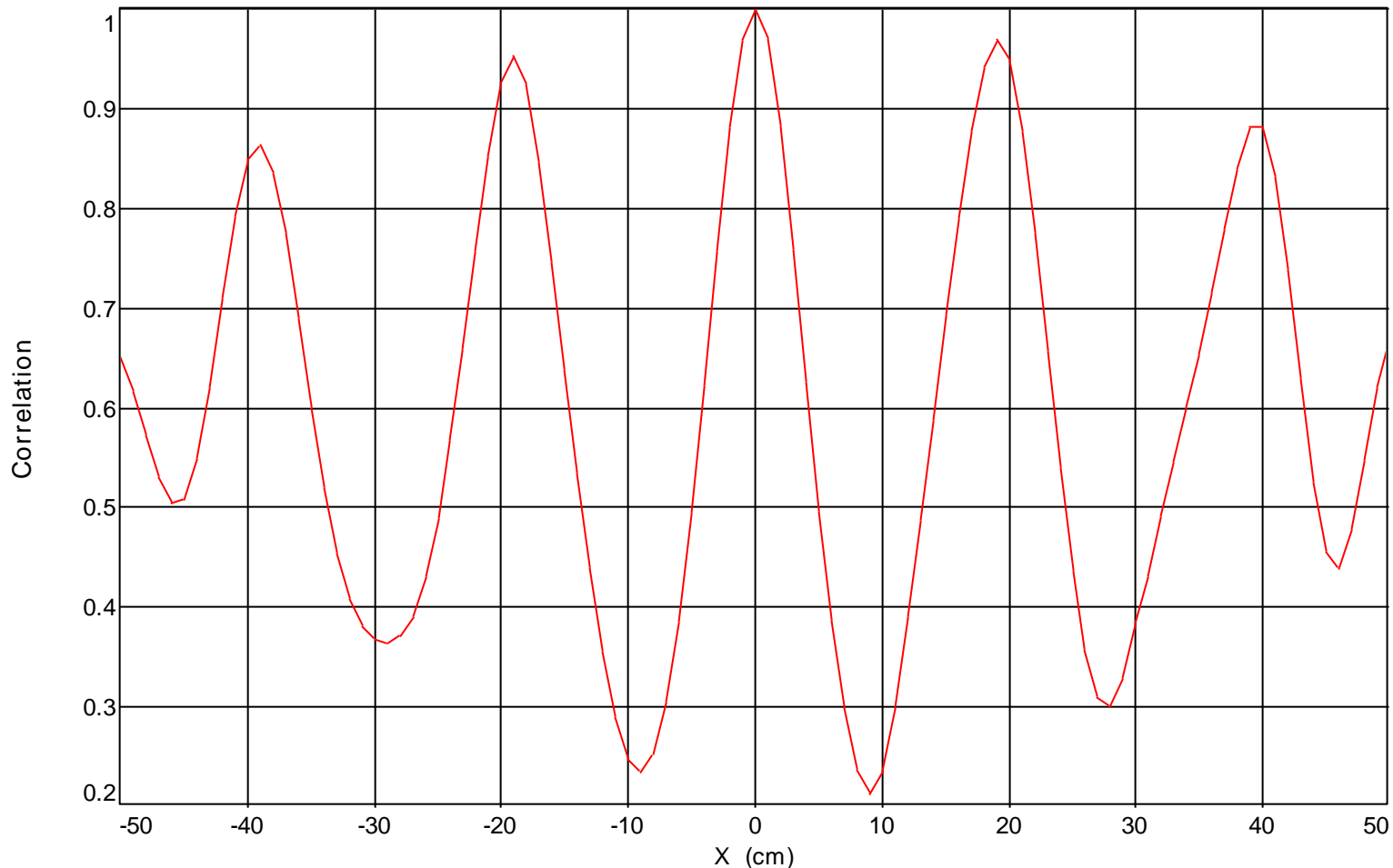

System Validation

■ Both tests show similar system performance results.

Comparison of Spatial Correlation and Field Structure for 22.5° Resolution Configuration

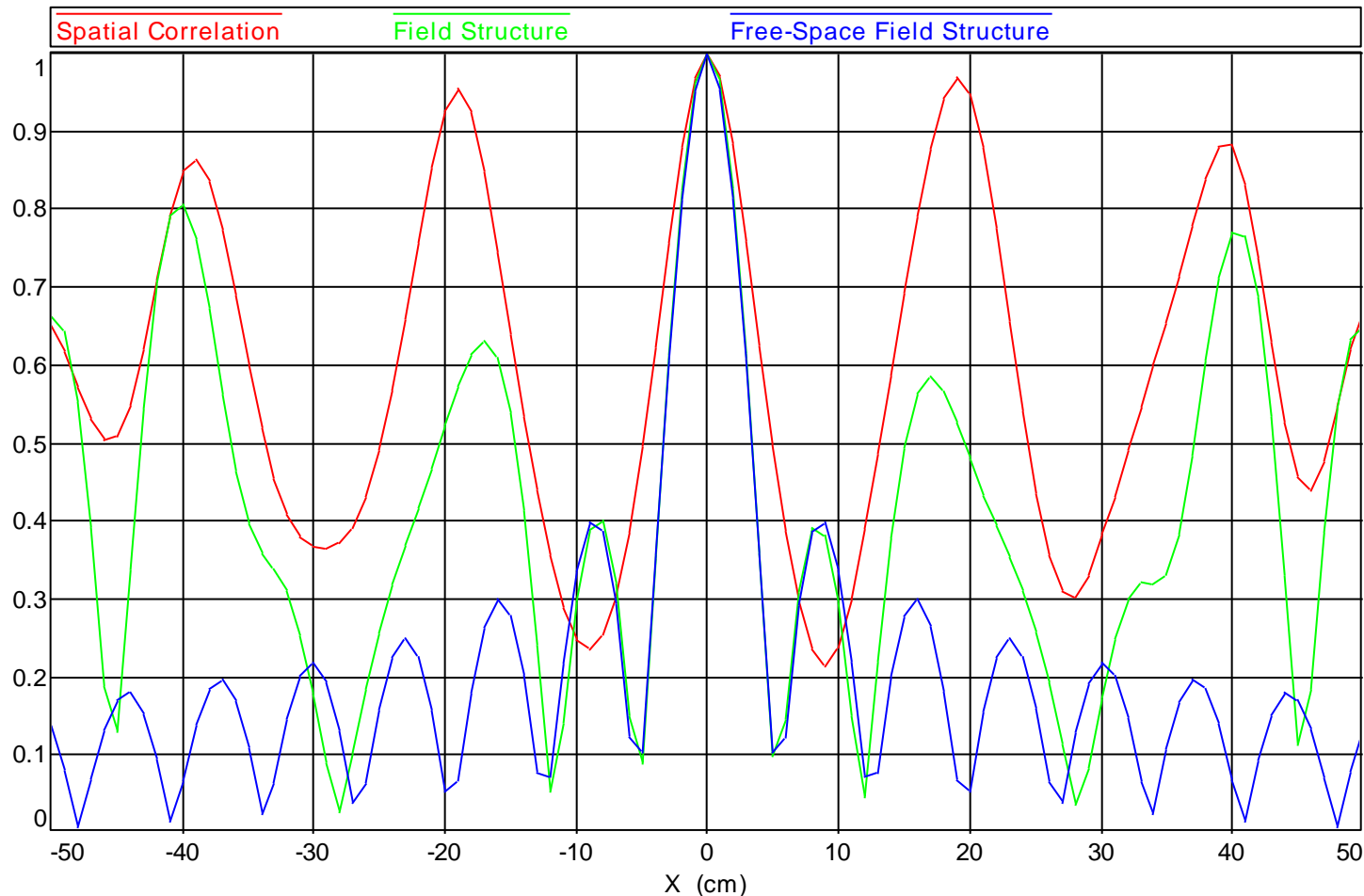

System Validation

- **Channel Model Pattern – Using a narrow beam antenna, the generated angular spread profile can be mapped.**
 - Works well as a quick verification for single cluster
 - Not as agile for more complicated models
- **Antenna-by-Antenna Mapping – Measure channel frequency response of each antenna across statistically large set of IR steps and TD transform.**
 - Evaluates PDP and AS of channel model.
 - Can be numerically compared to summation of all antennas active (requires valid phase calibration).

Throughput Measurement Results

- Unlike traditional TRP/TIS tests, which provide edge of link performance metrics, MIMO performance is all about high bandwidth with large SNRs.
- The corresponding metric for measuring bandwidth is throughput, and the equivalent evaluation would be to determine when the throughput begins to fall off.
- Initial tests were performed with 802.11n devices supporting 2x2 MIMO, to prove the capabilities of the system and methodology.
- Now that LTE communication testers are available, it is possible to show the first LTE MIMO OTA results.

Wi-Fi Throughput Measurement Results

- A re-configurable MIMO OTA system was installed in ETS-Lindgren's Cedar Park facility for research and development of test requirements.
- Eight dual polarized antenna elements were mounted on adjustable fixtures and arranged around a DUT positioning turntable.
- The Elektrobit PropSim F8 channel emulator was used to provide the spatial channel emulation required for the OTA environment simulation.
- Eight 30 dB gain power amplifiers drive eight vertical antenna elements.

Wi-Fi Throughput Measurement Results

- An 802.11n 2x2 MIMO Wireless Router with removable, adjustable external antennas was chosen as the DUT.
- A matching NIC was used as the downlink source.
- Directly cabled conducted tests were used to verify MIMO operation with appropriately higher throughput compared to SIMO/SISO cabled configurations.



Wi-Fi Throughput Measurement Results

- **Conducted tests of throughput vs. attenuation were performed with PropSim F8 using circulators/isolators to provide a single return uplink.**
- **Direct single tap models were used to replicate cabled results.**
- **Several 2x2 MIMO models suitable for OTA testing were evaluated to determine typical MIMO performance.**
 - Modified SCME Urban Micro w/ 3 km/h fading & zero delay spread.
 - Modified TGn-C w/ AOD/AOA based on SCME
 - Modified TGn-C w/ low TX correlation (10 wavelength sep.)

Wi-Fi Throughput Measurement Results

- Using standard 20 MHz 802.11 channels, conducted tests show maximum SIMO throughput around 25 MBPS, with MIMO performance around 40-45 MBPS with typical channel models.
- Initial OTA tests with stock antennas using low correlation TGn-C OTA model produces similar results but shows angular dependence of MIMO performance while SIMO (diversity) performance remains uniform.

Wi-Fi Throughput Measurement Results

Throughput vs. Total Path Loss

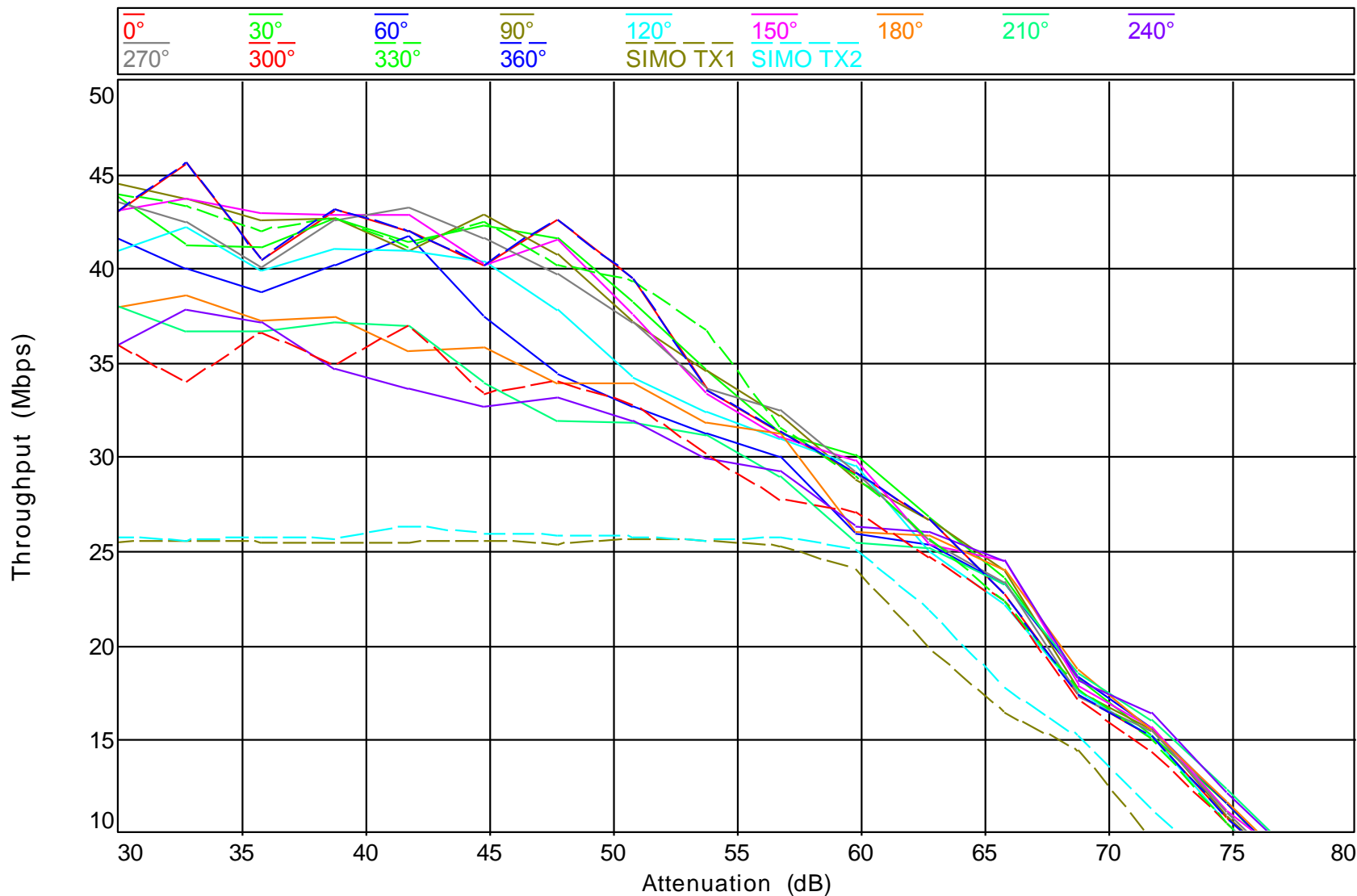

Wi-Fi Throughput Measurement Results

Throughput vs. Total Path Loss

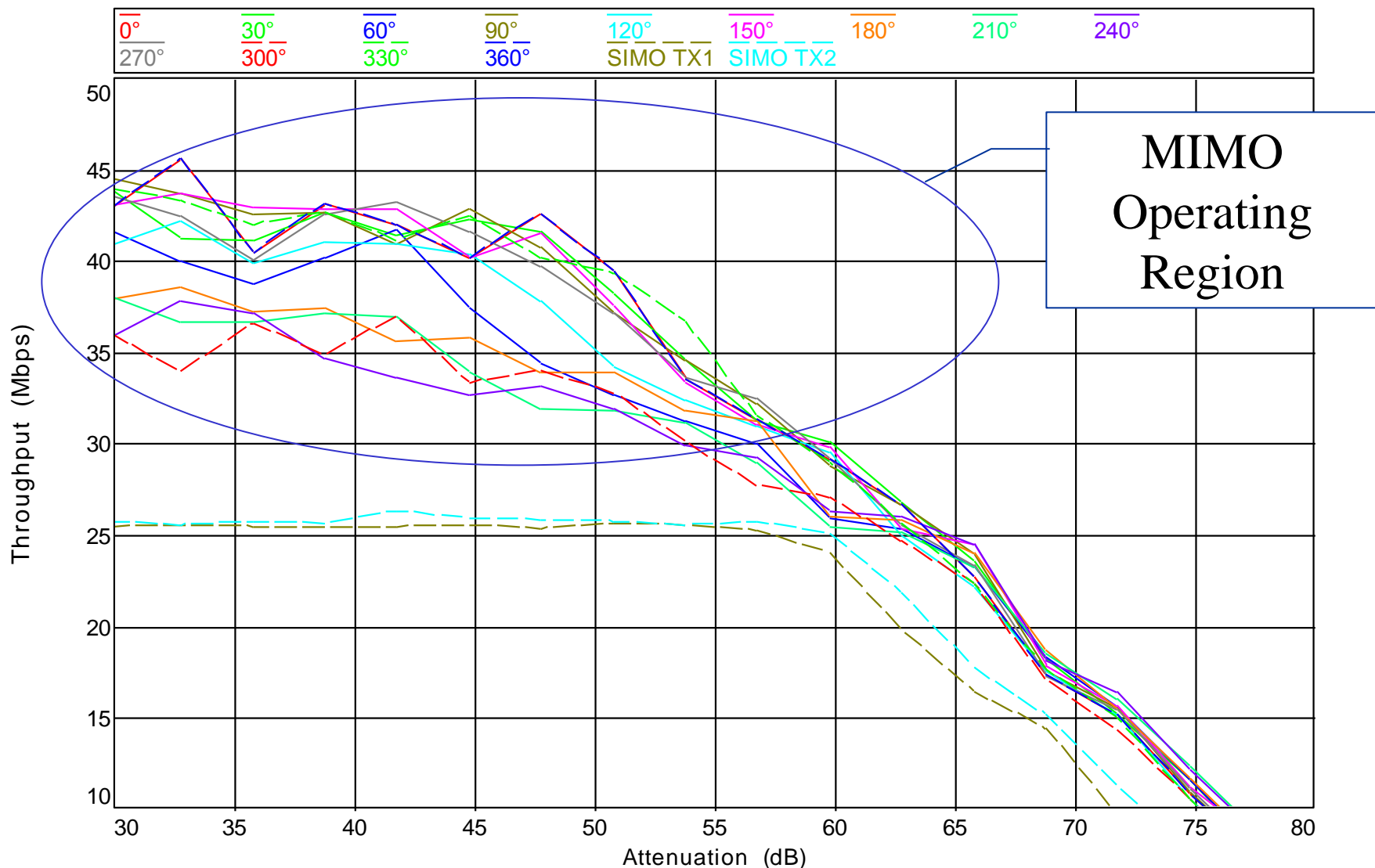

Wi-Fi Throughput Measurement Results

Throughput vs. Total Path Loss

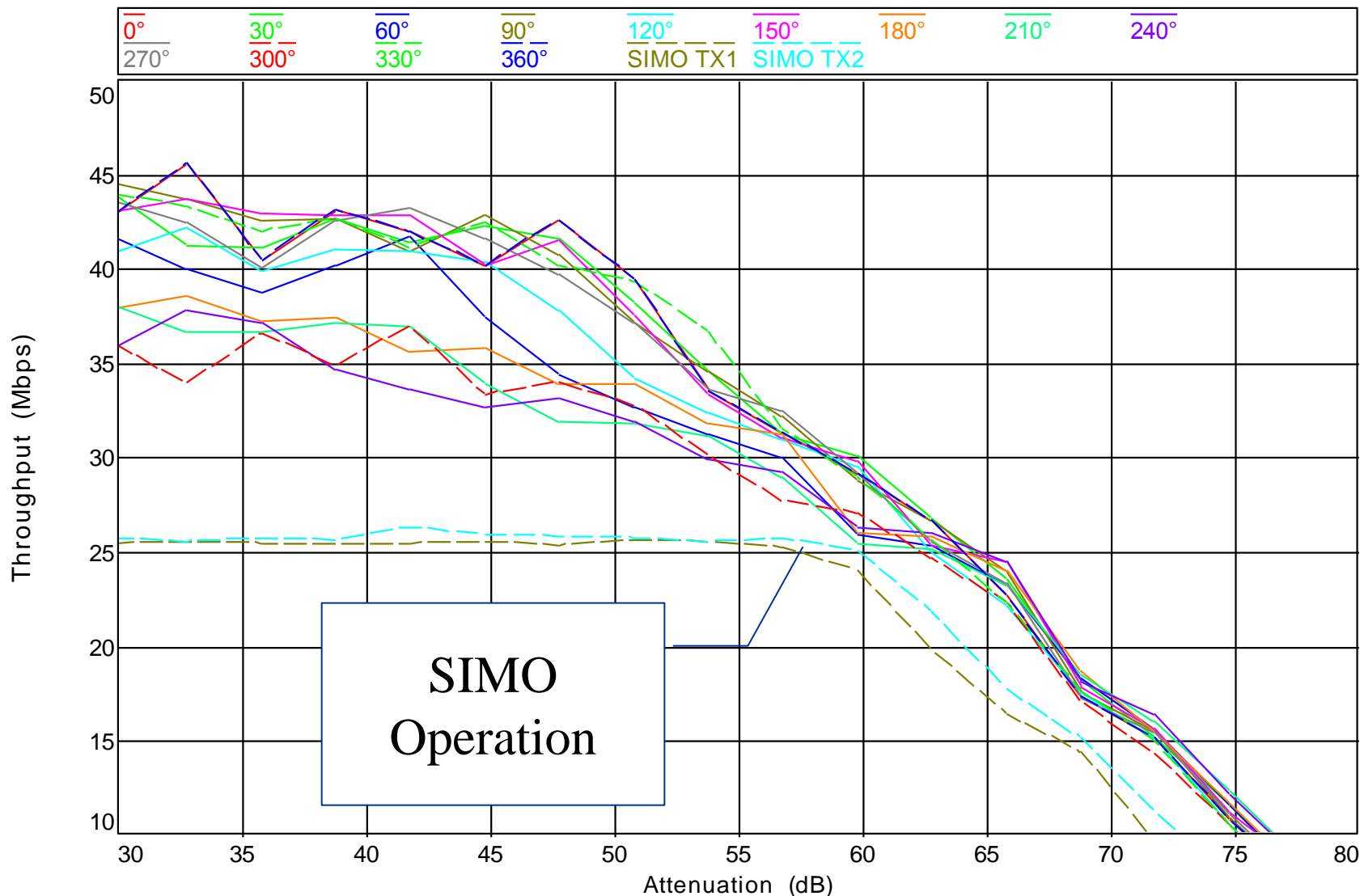

Wi-Fi Throughput Measurement Results

Throughput vs. Total Path Loss

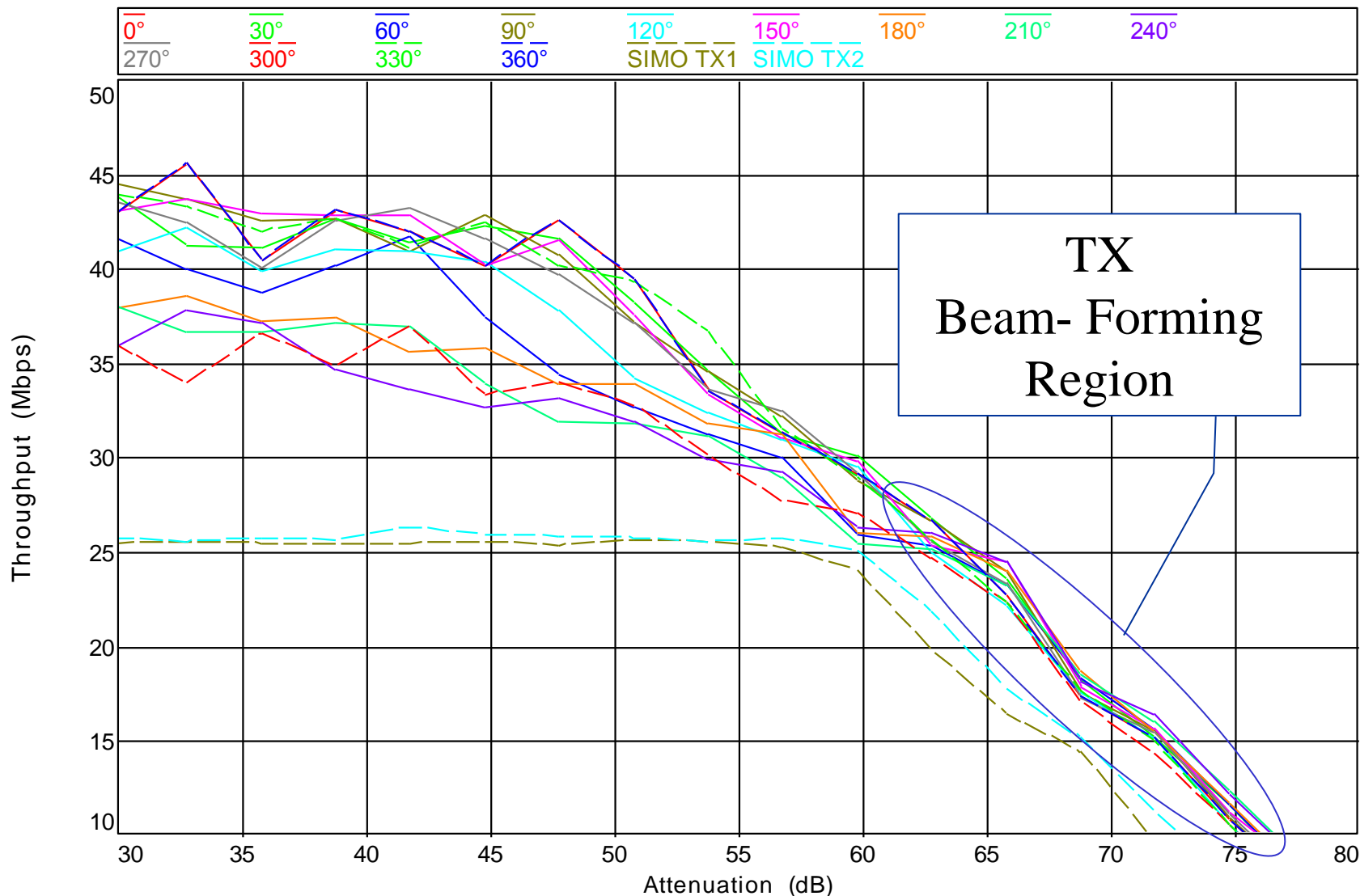

LTE Throughput Measurement Results

- LTE USB modem on test pedestal in middle of chamber



LTE Throughput Measurement Results

Throughput vs. Power vs. Orientation, SCME Urban Micro, 16 QAM LTE DUT

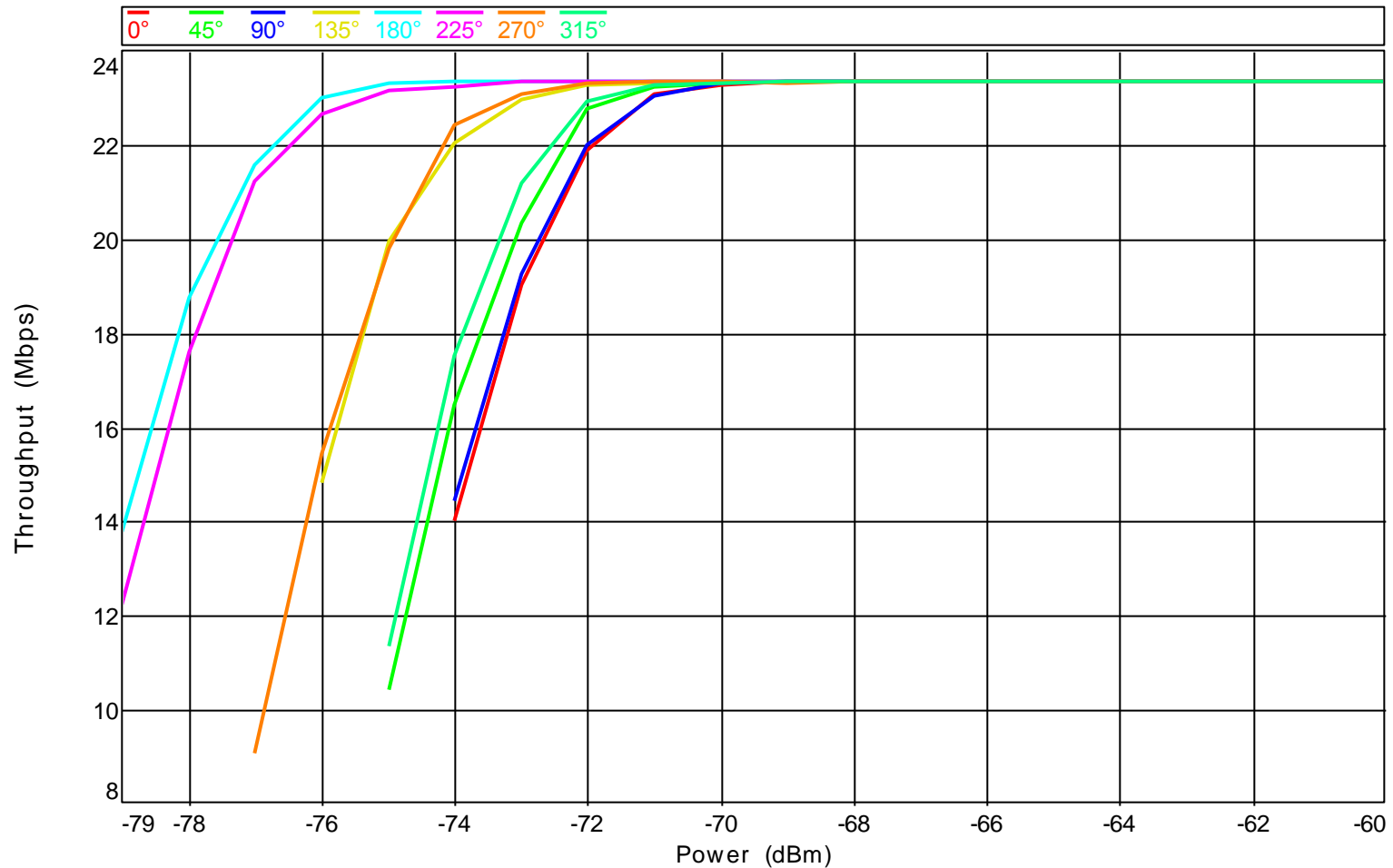

LTE Throughput Measurement Results

20 Mbps Throughput Sensitivity Pattern, 16 QAM LTE DUT

6.2.1 - SCME Urban Micro, Avg = -74.0 dBm
6.2.3 - SCME Urban Macro, Avg = -74.5 dBm

6.2.2 - Modified SCME Urban Micro, Avg = -74.4 dBm
6.2.4 - Modified WINNER2, Avg = -73.1 dBm

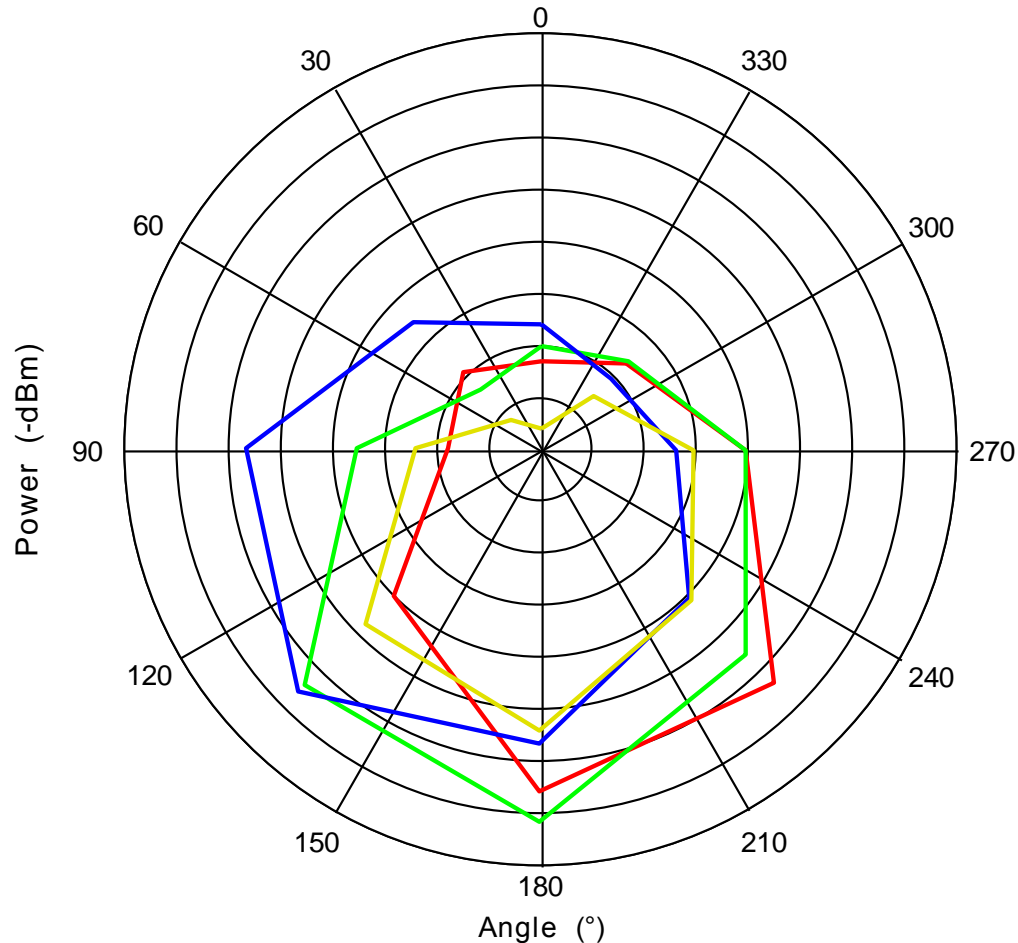

Max: 79
Min: 71
Scale: 1/div

LTE Throughput Measurement Results

40 Mbps Throughput Sensitivity Pattern, 64 QAM LTE DUT

6.2.1 - SCME Urban Micro, Avg = -61.1 dBm
6.2.3 - SCME Urban Macro, Avg = -58.8 dBm

6.2.2 - Modified SCME Urban Micro, Avg = -61.0 dBm
6.2.4 - Modified WINNER2, Avg = -60.6 dBm

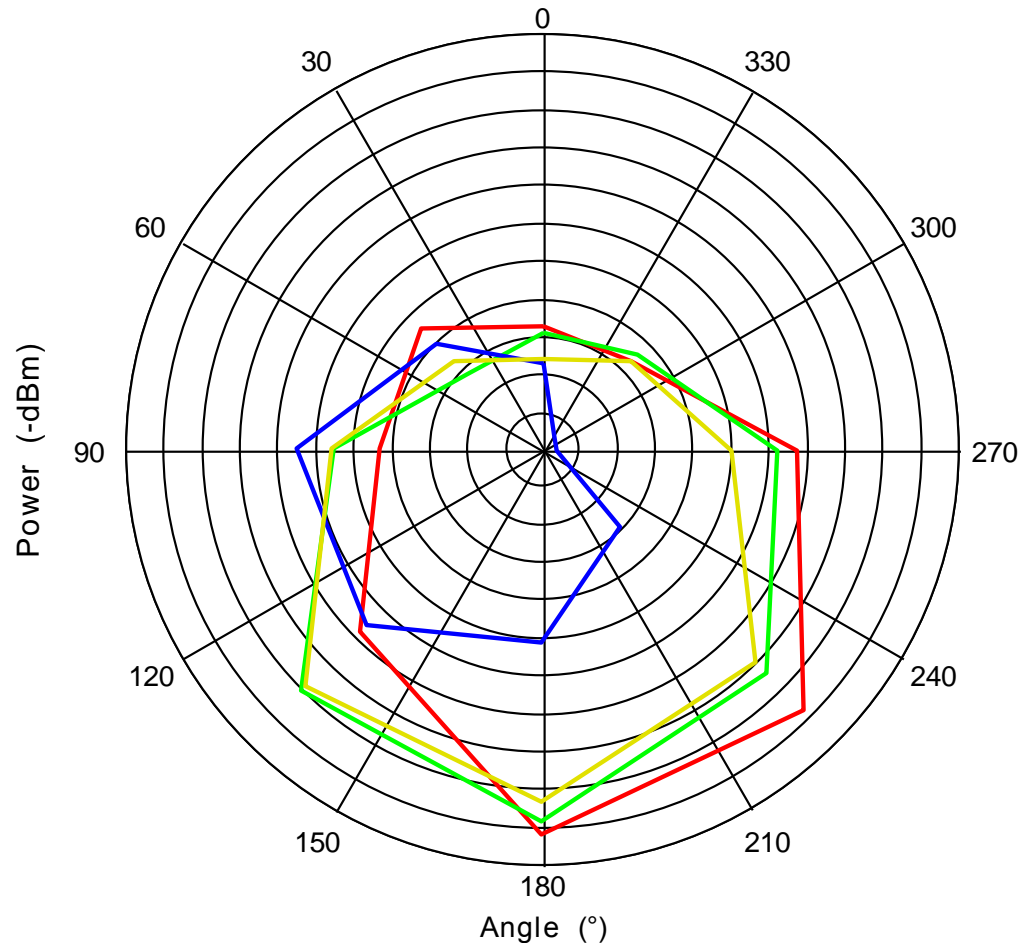

Max: 67
Min: 56
Scale: 1/div

Metrics

- **The data acquired thus far can be evaluated in a number of ways to define different metrics for MIMO performance.**
- **Removing the position axis produces average throughput vs. power (attenuation) curves.**
- **This could be done as a post processing step, but if position (pattern) information is not needed, average throughput performance can be determined by moving DUT continuously through simulated environment.**

Metrics

Average Azimuthal Throughput vs. Total Path Loss

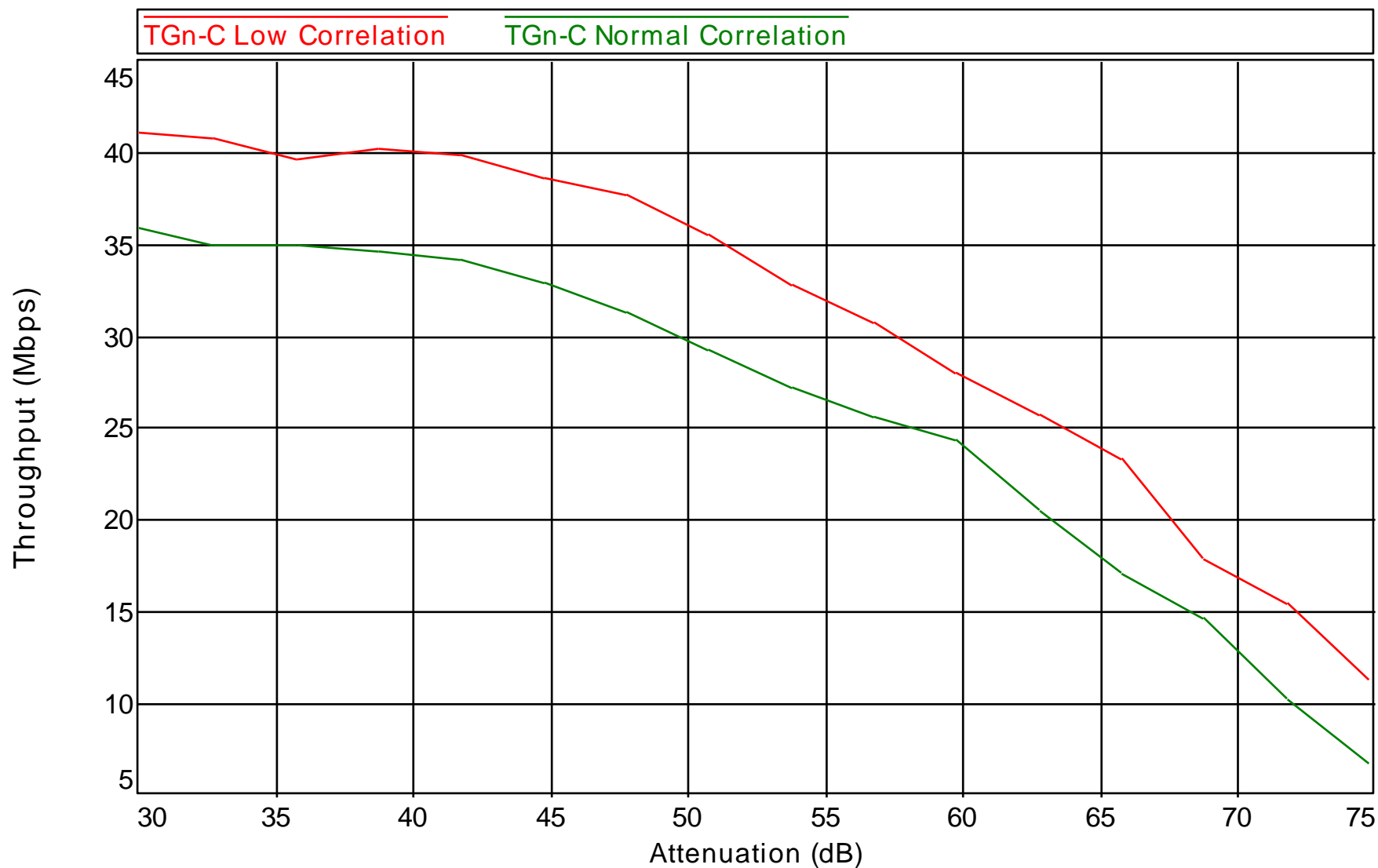

Metrics

- **This test can be further reduced by choosing to determine average throughput performance at a given field level (no power level search).**
 - E.g. At an attenuation value of 50 dB, this DUT has an average throughput of 36 Mbps for the low correlation TGn-C model and 30 Mbps for the normal correlation TGn-C model.
- **This is similar to many conformance tests with a simple pass/fail result, and assumes a minimum expected network capability.**

Metrics

- **By retaining angular information, or by measuring throughput over short dwell times as the DUT moves, peak throughput performance can be determined.**
- **This metric may have limited usefulness, but does illustrate a slightly different reaction to the two models.**

Metrics

Peak Azimuthal Throughput vs. Total Path Loss

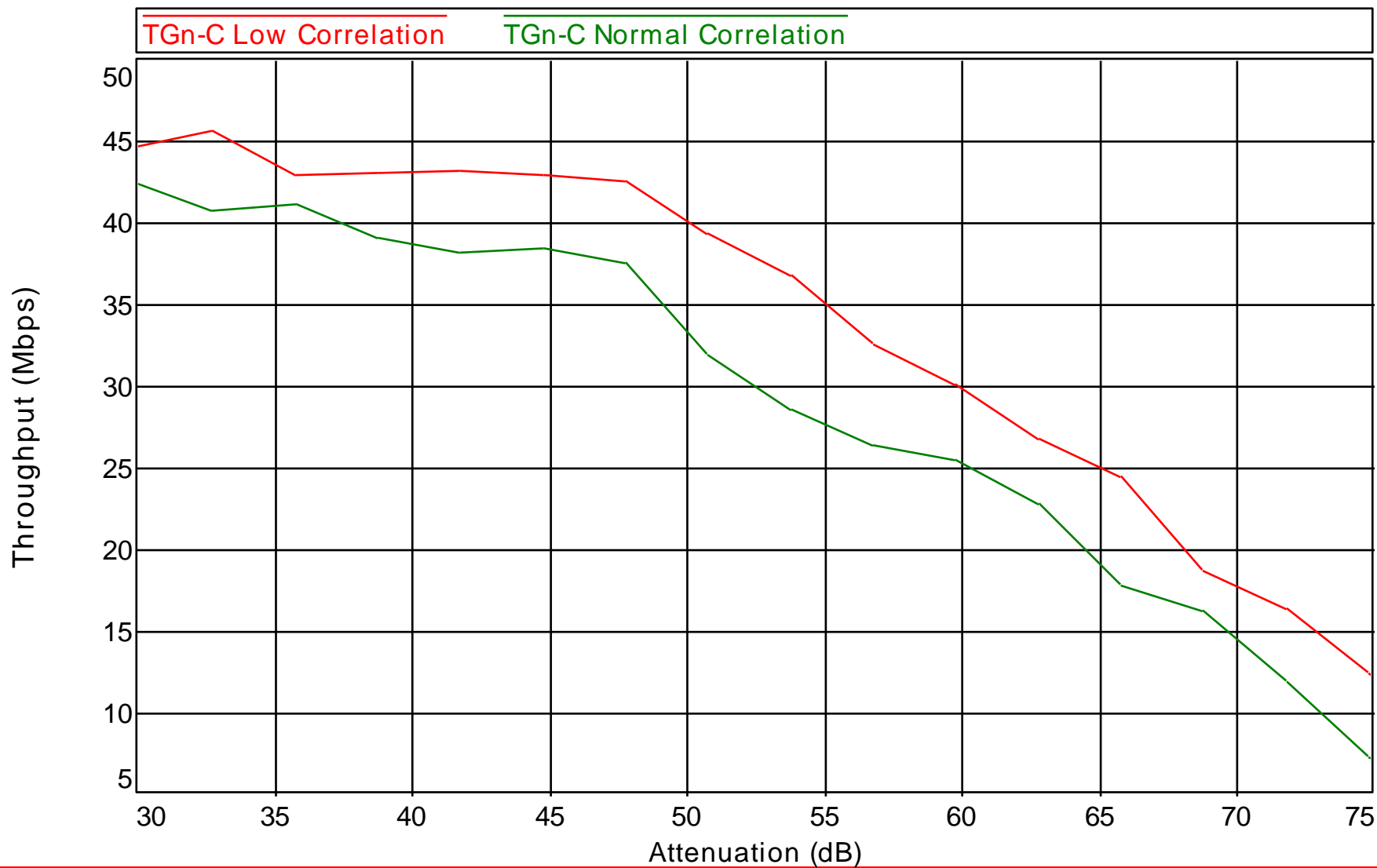

Metrics

- **By retaining throughput vs. attenuation or using a throughput vs. attenuation search mode, one can define a “MIMO Sensitivity” where throughput falls below a certain target.**
- **This can be defined in two ways, with varying test time requirements.**
 - Average power required to produce the target throughput at each angle (integrated TIS pattern)
 - Power required to produce desired average throughput as device is rotated through all angles

Metrics

(Linear) Average Attenuation vs. Throughput

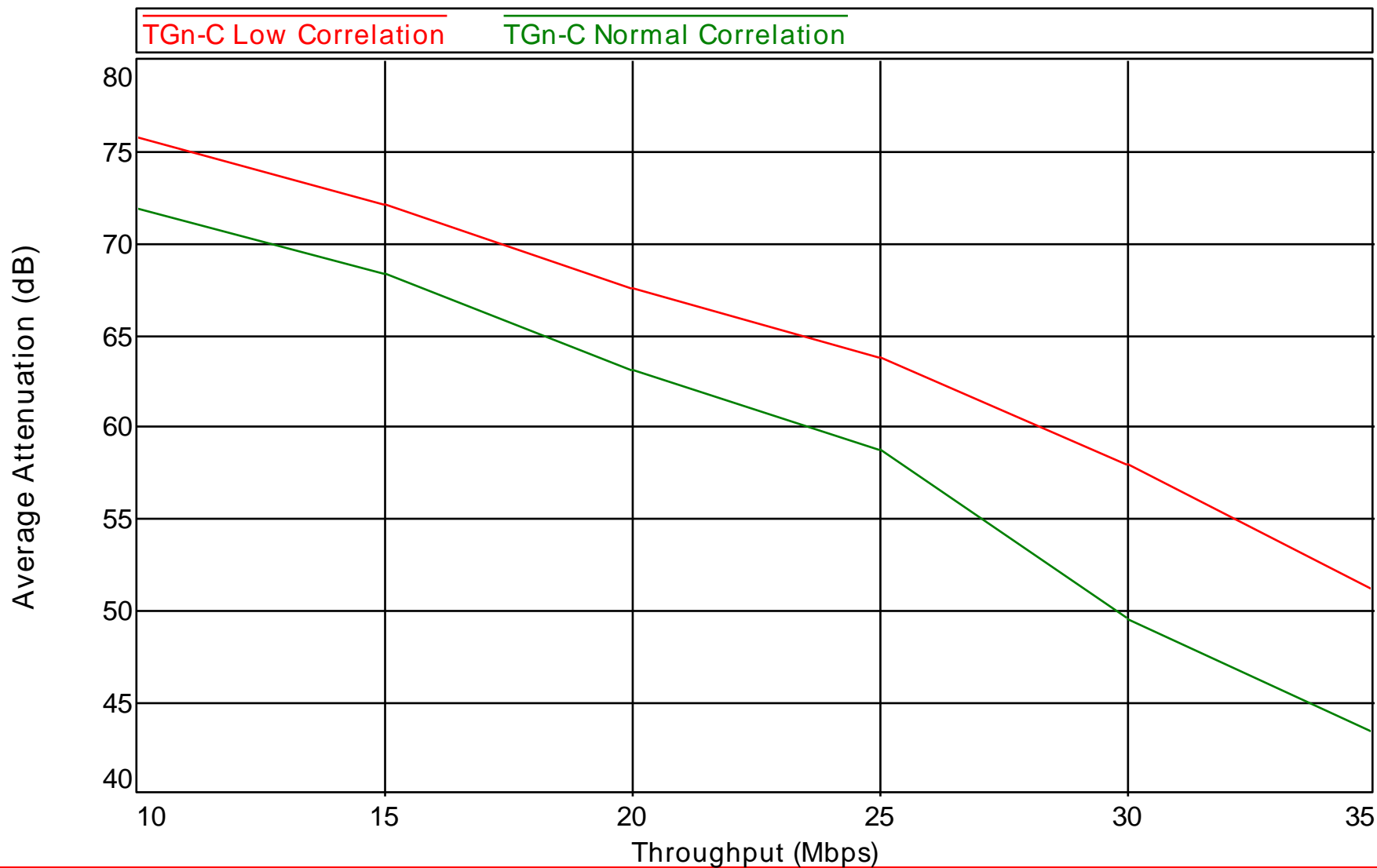

Metrics

- While the statistics of these two metrics are slightly different and provide slightly different results, both provide considerably more information on the DUT, offering an “edge of MIMO link” performance indicator.
- Such information can be used to rank products and influence improvements, while the previous pass/fail options only offer basic acceptability criteria.

Reference MIMO Antenna

- “Good” device antenna patterns.

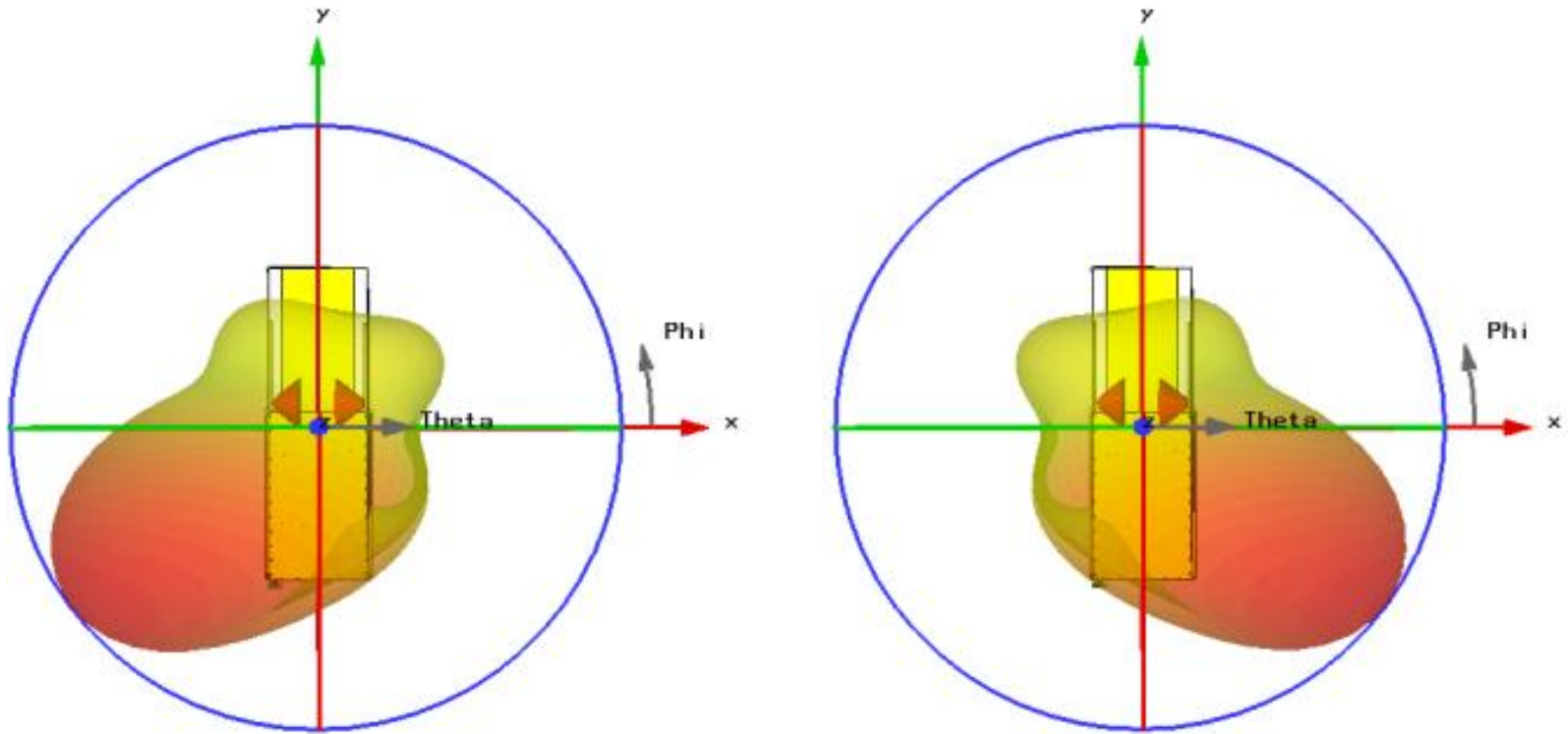

Reference MIMO Antenna

- “Nominal” device antenna patterns.

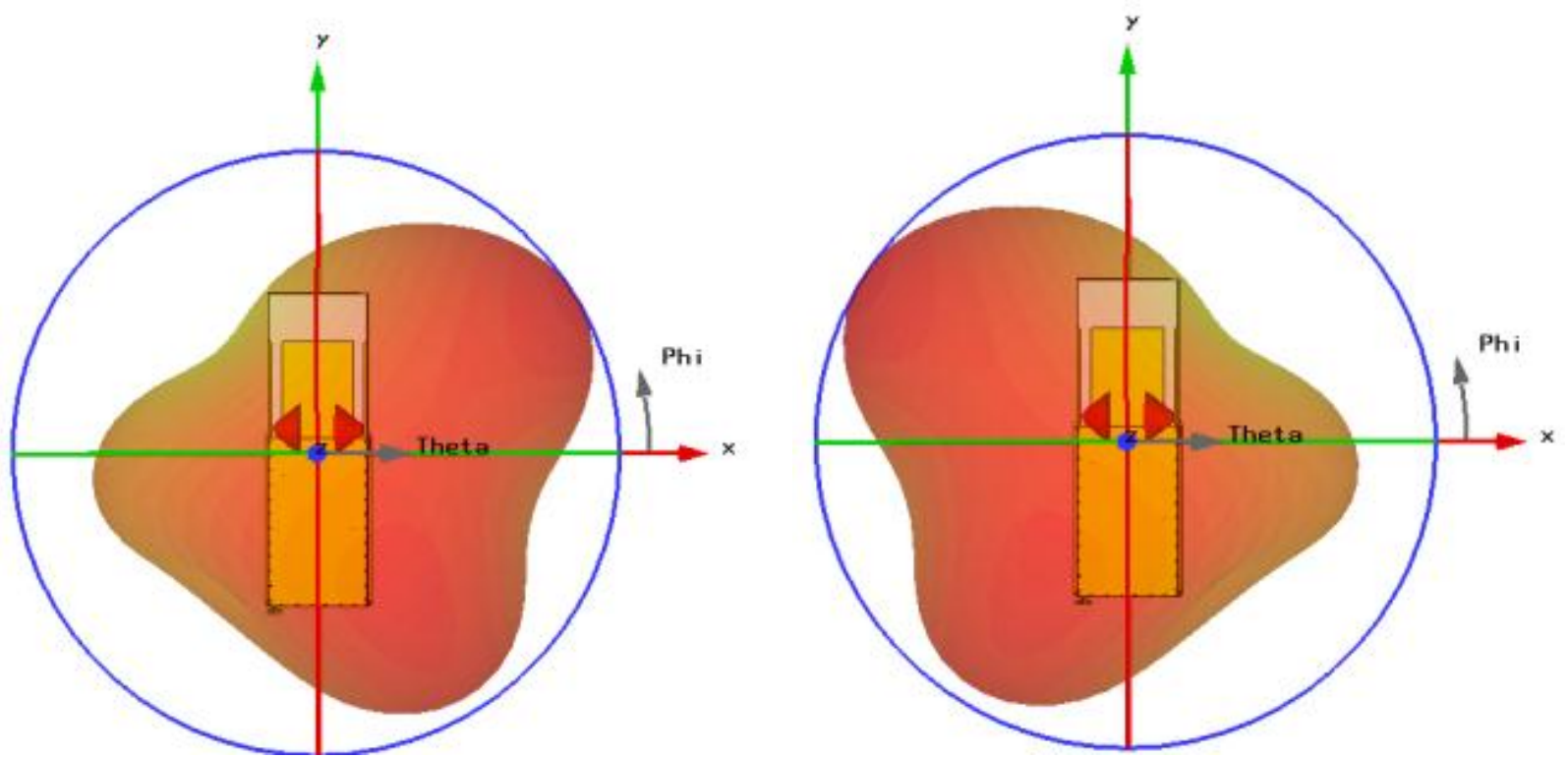

Reference MIMO Antenna

■ “Bad” device antenna patterns.

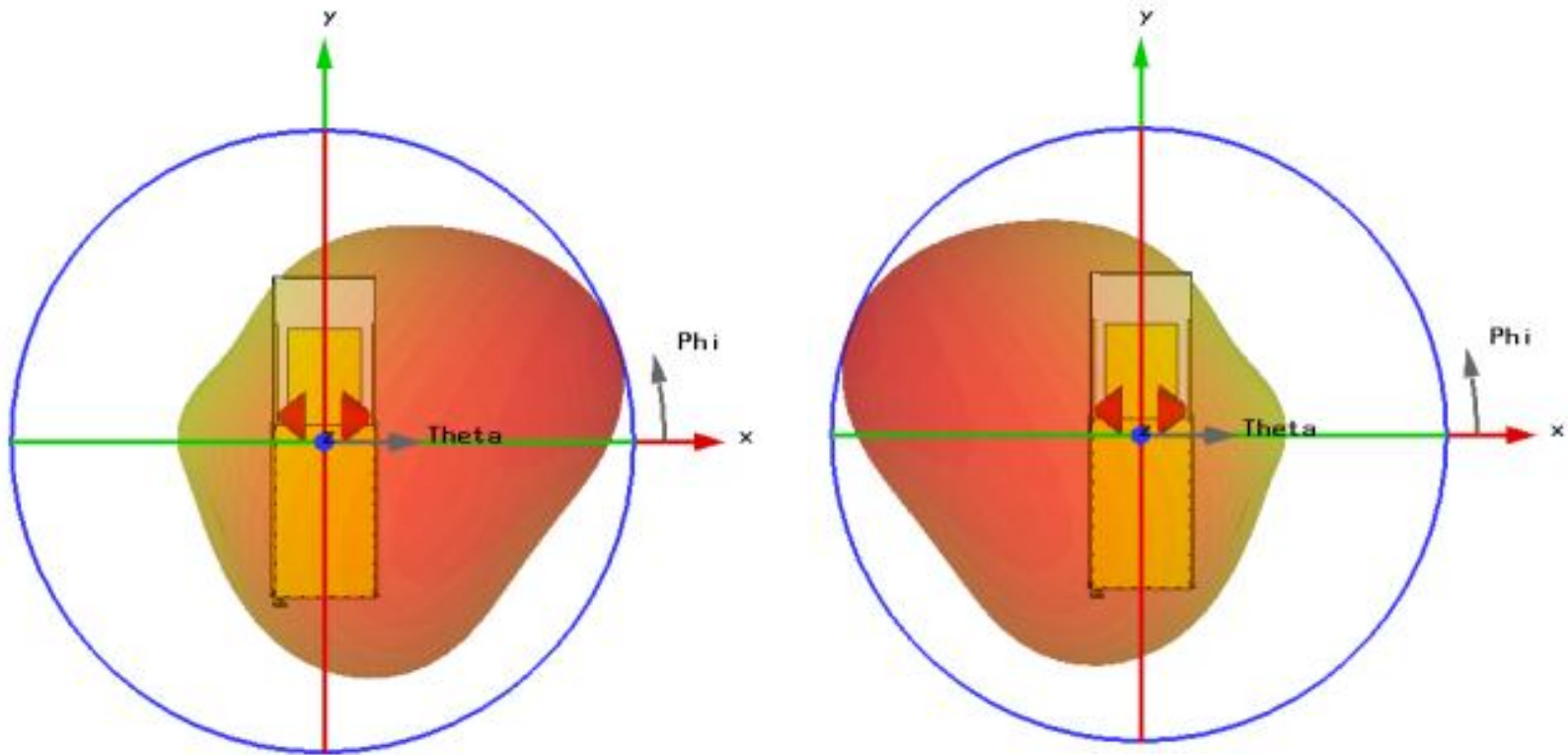

LTE Throughput Measurement Results

- Tests were performed in an AMS-8700 MIMO OTA system using eight vertically polarized elements evenly spaced every 45 degrees.

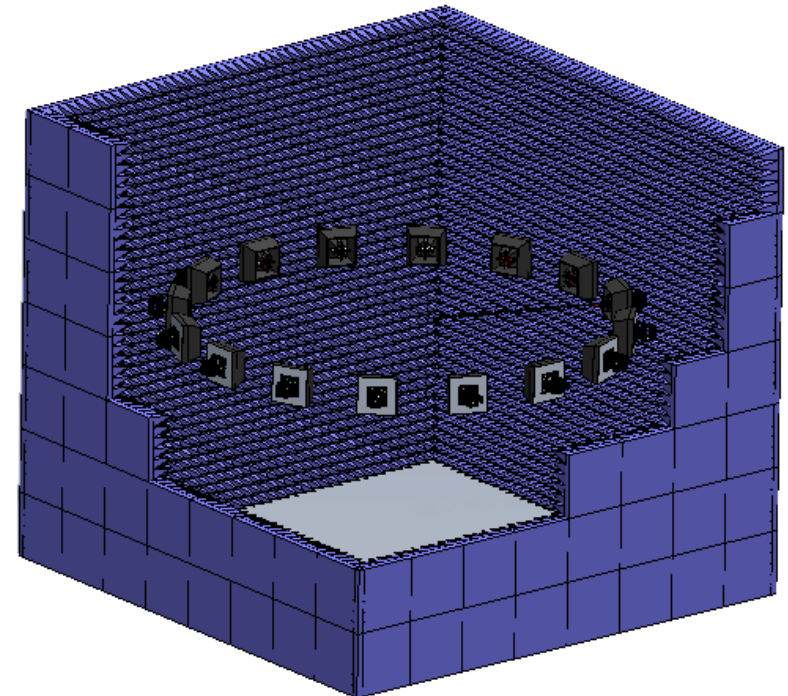
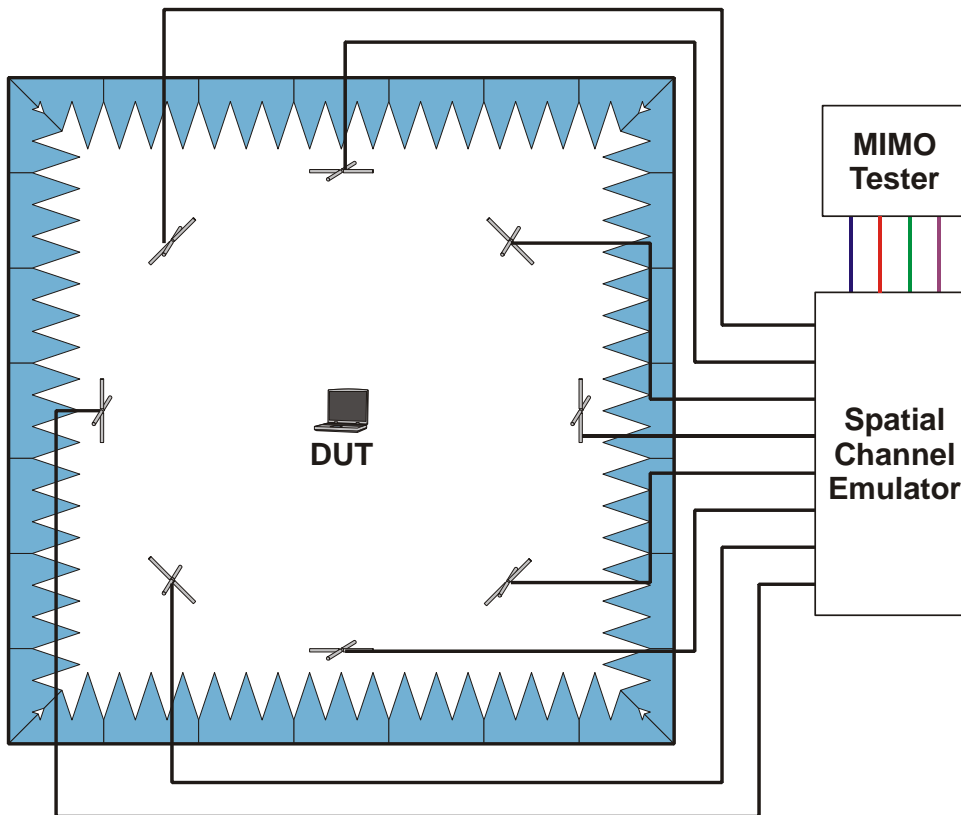

LTE Throughput Measurement Results

SCME Urban Micro (TR 37.976 Section 6.2.1), 30 km/h

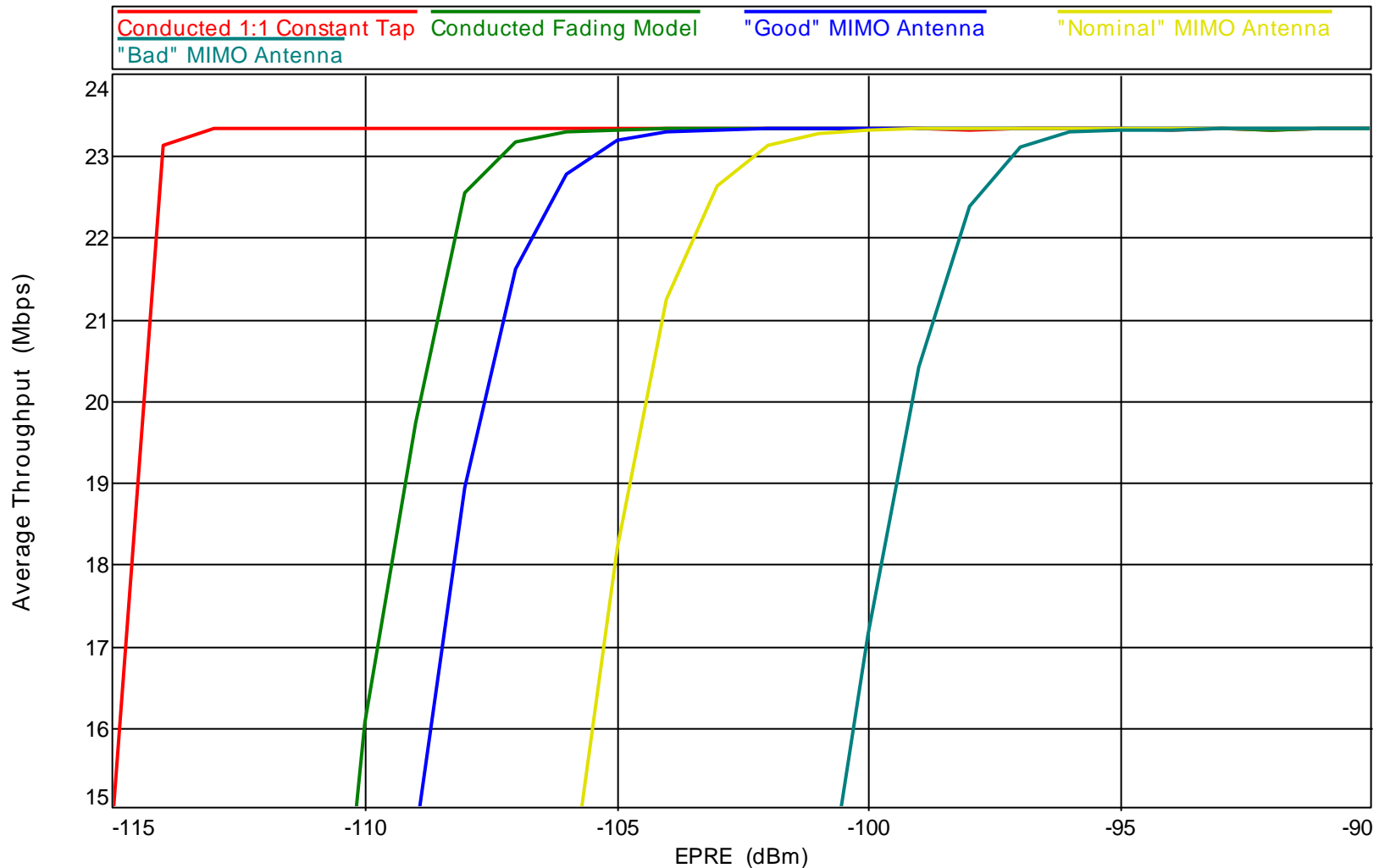

LTE Throughput Measurement Results

"Optimum Drop" Model, 30 km/h

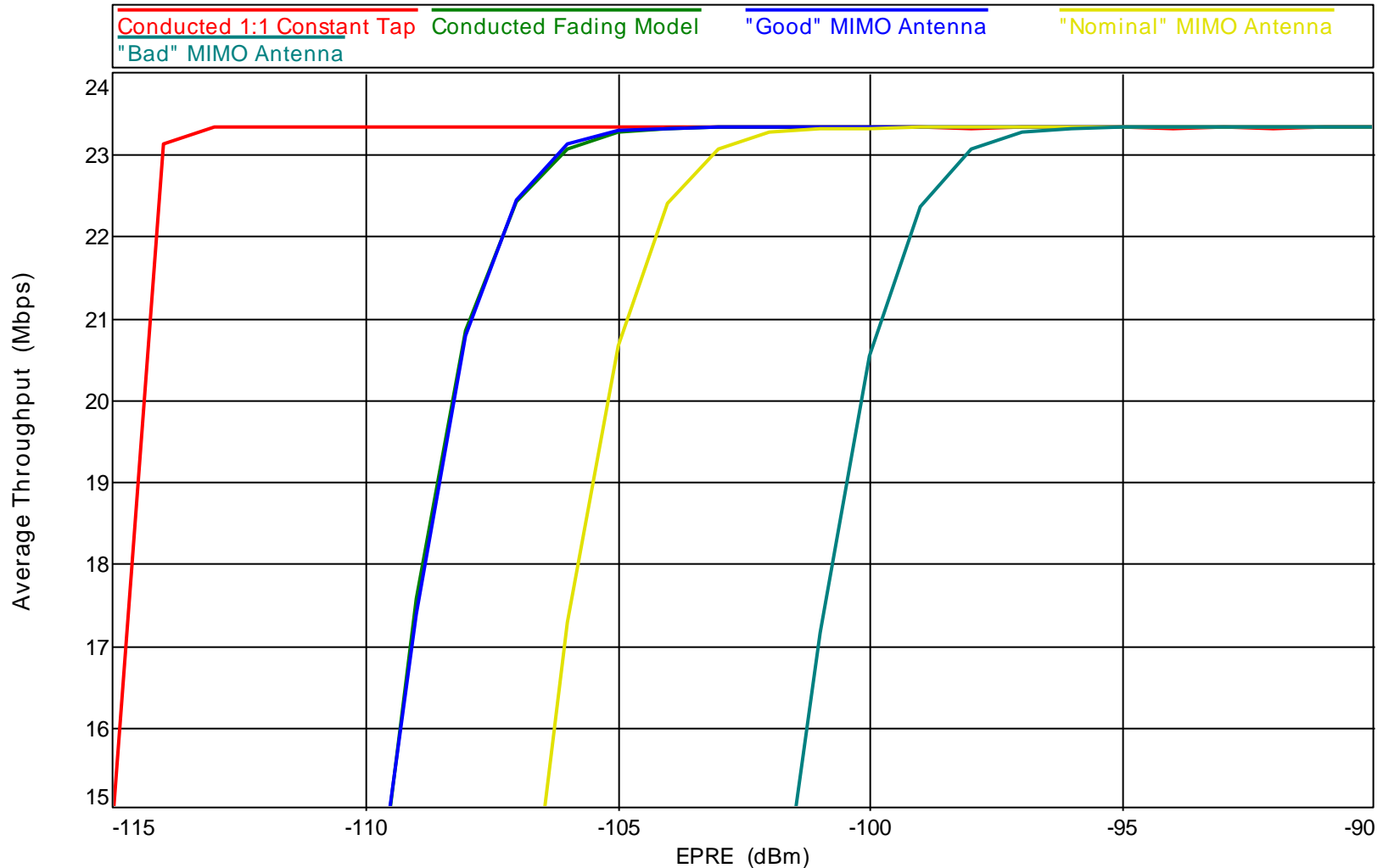

Reference MIMO Antenna

- With a measured <10 dB delta between a “good” and “bad” antenna, this method is good at differentiating between devices within the expected measurement uncertainty.
- Orientation of the device and polarization are expected to have an effect. This device was optimally oriented in the test system.
- Plans to repeat test with a dual polarized setup and possibly different orientations will follow.

Conclusion

- Extensive efforts are underway to standardize on a next generation platform for wireless testing.
- The ability to perform realistic RF environment simulation and evaluate end user metrics in real-world scenarios is an invaluable resource to wireless technology developers.
- Detailed calibration and validation methods are required to ensure the validity of measured data.
- While a throughput related metric is the logical choice, the industry must still choose the desired target metric (e.g. throughput sensitivity).

Thank You!

Rome 2012



QUESTIONS?

Garth D'Abreu
Director of RF Engineering
Garth.dabreu@ets-lindgren.com
+1-512-531-6438

Dr. Michael D. Foegelle
Director of Technology
Development
foegelle@ets-lindgren.com
+1-512-531-6444